

READY

THE INNOVATOR OF OUR INDUSTRY®

# Compact Nitrogen Die Systems

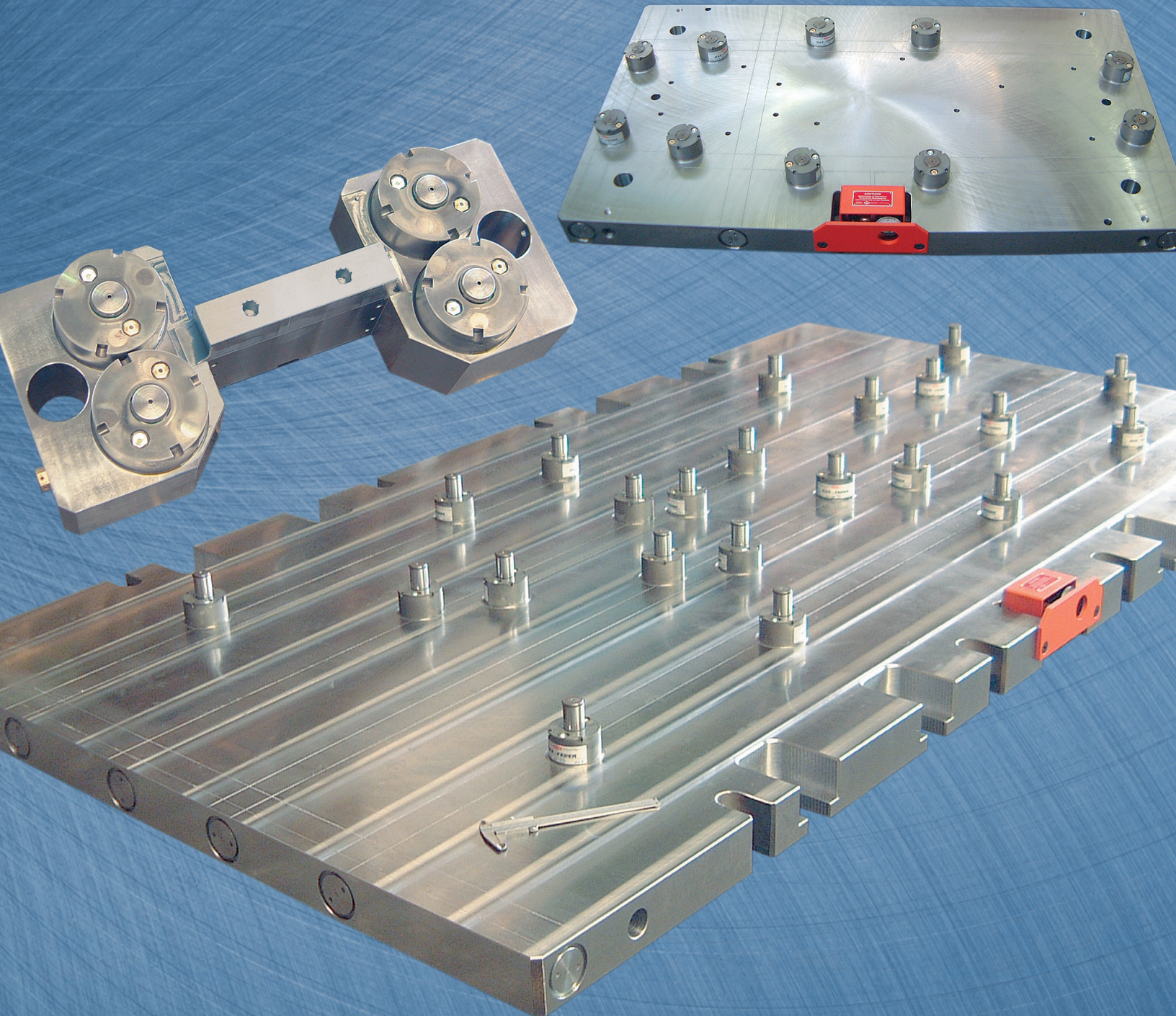

<b>CONTENTS</b>	<b>2</b>
Compact Die Systems Fundamentals	3
Spring rates and scales	4-5
Standard cylinders Type CDS (3.3 - 100 kN)	6
Pad mounted cylinders Type CDSP (3.3 - 200 kN)	7
Low profile cylinders Type CDSN (3.3 - 100 kN)	8
Pancake cylinders Type CDSK (10 - 55 kN)	9
Cylinders Type KNPF/KNPFP 1; 2,5; 5,5	10
Spare Parts	11
Manifold plate design and assembly	12-14
Small tanks Type NP - T / Threaded Tanks Type TDN - R	15
Custom welded tanks Type NPT (Up to 100 litres)	16
Control consoles Type KA	17-18
Volume calculation	19
Port plugs and safety plugs	20
Fittings and hoses	21-22
Bottle fill unit NPA 110.01	23

## COMPACT DIE SYSTEM FUNDAMENTALS

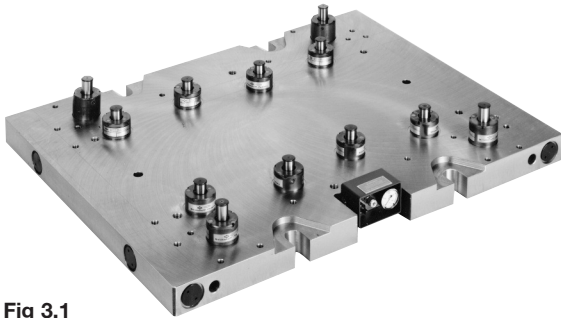

Fig 3.1

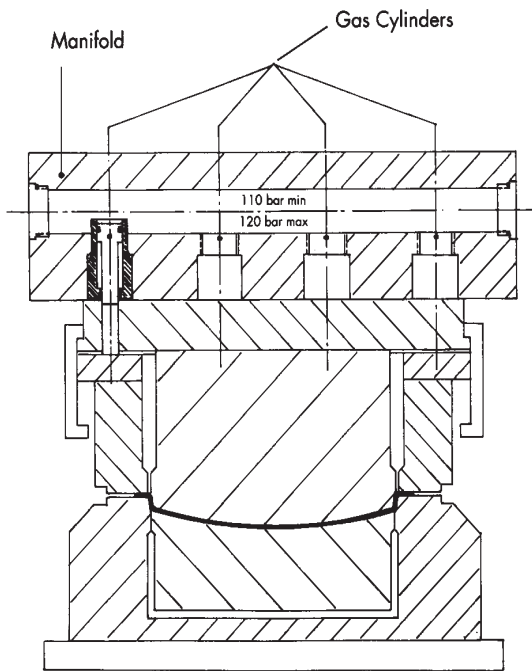

Fig 3.2

### Manifold System

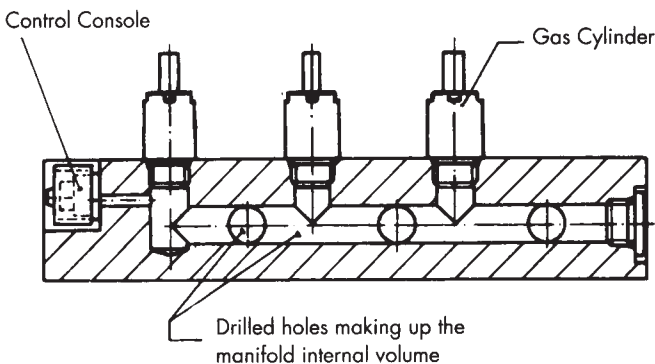

Fig 3.3

COMPACT DIE SYSTEMS use cylinders mounted into a manifold plate with drilled gas ways, or as individual components connected by hoses to a reservoir tank (figure 3.4). The initial gas pressure is normally 110 bars, while the final pressure at the maximum piston stroke is 120 bars. These systems produce forces ranging from 3.3 to 200 kN per cylinder.

The temperature varies according to press speed and stroke length, up to 40°C.

The nitrogen gas charging pressure, and thus the piston force is easily and rapidly adjusted by means of a control console. Operational safety is ensured by the use of tested tanks and safety plugs.

COMPACT DIE SYSTEMS provide an almost constant force throughout the stroke. The desired force can be easily obtained by adjusting the gas pressure.

Since all cylinders are connected and subject to the same pressure, each cylinder exerts the same force. A leak in any part of the system will not produce an off center load which could compromise part quality.

The new COMPACT DIE SYSTEM developed by READY provides a number of features previously lacking in first generation gas cylinders. There is no breathing port which could draw in contaminants and the system is hermetically sealed. A lubrication system is integrated into the cylinder design which not only reduces wear but ensures good sealing and extended seal life. Furthermore this system can be maintained without removing the cylinder from its base or manifold.

### External Hose and Tank System

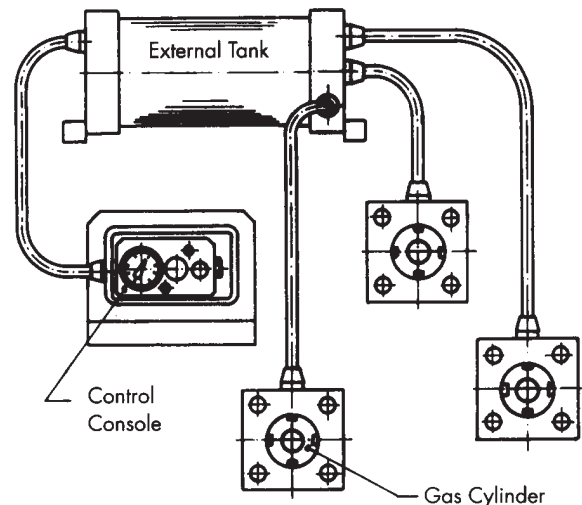

Fig 3.4

## SPRING RATES

READY NITROGEN SPRING = almost ideal spring rate - little space occupied

Concerning a spring system the most interesting for a designer in construction or production is the spring rate and the required space occupied. The example, which shows in scale the real space between a spring and READY NITROGEN SPRING, is applicable for all READY nitrogen springs. In comparison to other spring systems the Ready spring saves 50 to 70% of space – not only the die spring.

That means maximum power in lowest space.

All benefits will be shown in the scales of the next page, when you compare the spring systems with the READY NITROGEN SPRING SYSTEM.

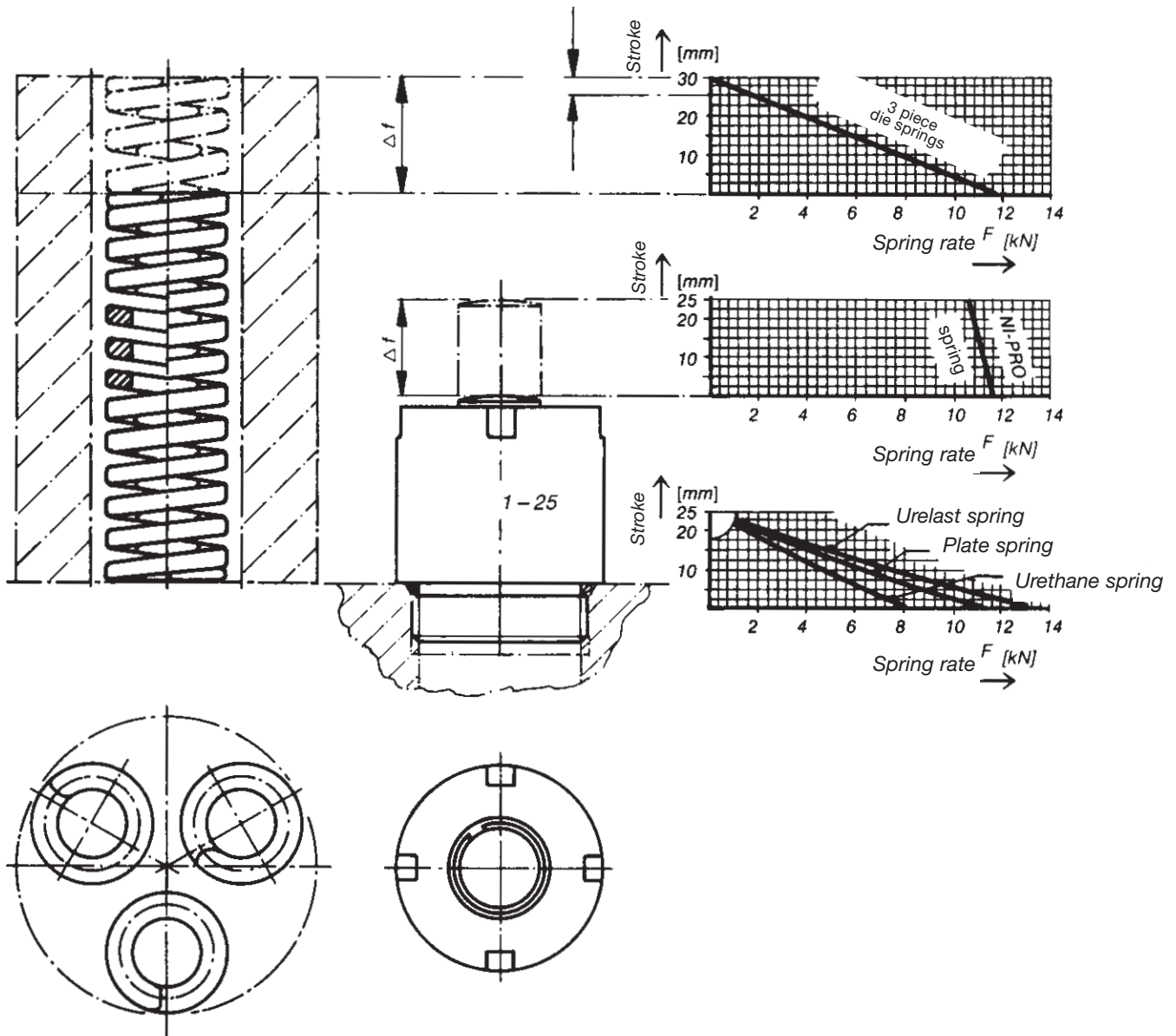

# NITROGEN GAS SPRINGS CHARTS

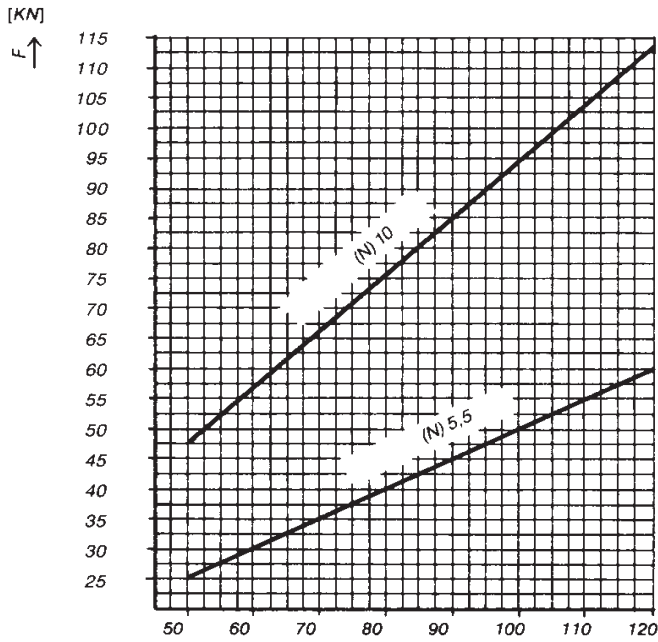

The figures shows the spring rate in kN and the pressure in bar.

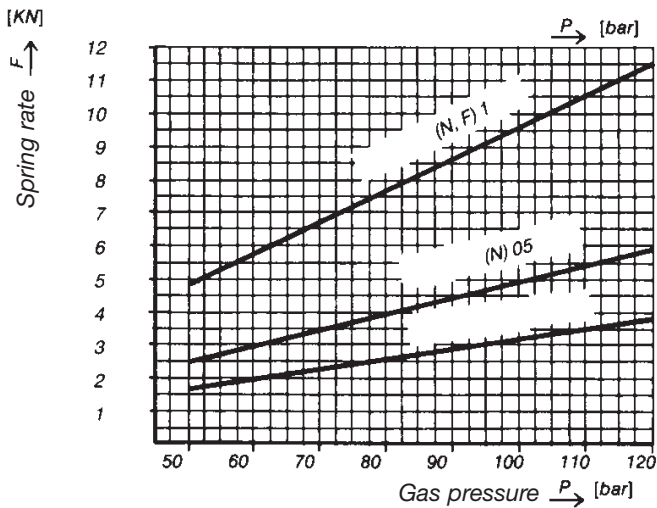
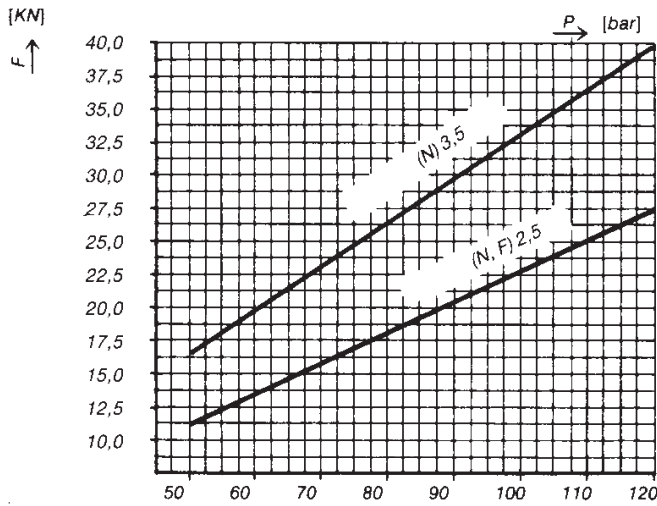

## STANDARD CYLINDERS TYPE CDS

MODEL	NOM. FORCE KN	S T R O K E						
		12.5	25	38	50	75	100	150
CDS 0.3	3.3	•	•	•	•	•	•	
CDS 0.5	5.0	•	•	•	•	•	•	
CDS 1.0	10		•	•	•	•	•	
CDS 2.5	25		•	•	•	•	•	
CDS 3.5	35		•	•	•	•	•	•
CDS 5.5	55		•	•	•	•	•	•
CDS 10	100		•	•	•	•	•	•

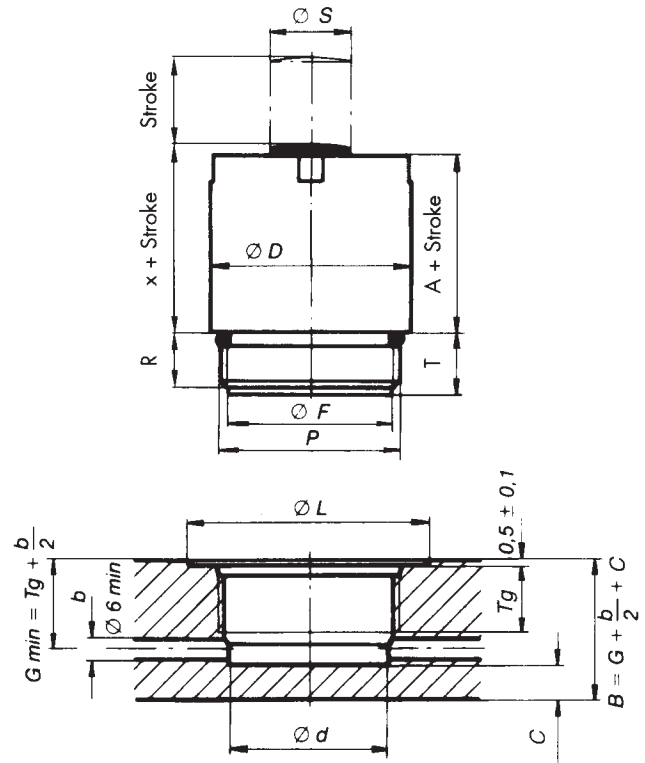

MODEL	A	X	ØD	Ød	ØL	ØF	ØS	T	R	P	Tg	Øb min	C min
CDS 0.3	15.3	17.0	32	23	44	22.5	10	16	15	M27 x 2	20	6	6
CDS 0.5	18.8	20.5	42	32	50	31.5	12	15	15	M36 x 2	20	6	8
CDS 1.0	21.8	23.5	54	44	65	42.0	22	15.5	15	M48 x 2	20	6	10
CDS 2.5	21.8	23.5	70	60	80	59.5	28	17	15	M64 x 2	20	6	10
CDS 3.5	31.5	33.5	88	77	92	76.0	28	19.5	18	M80 x 2	23	8	10
CDS 5.5	36.5	38.5	108	96	112	95.0	40	25	20	M100 x 2	25	12	13
CDS 10	41.5	43.5	146	126	151	124.5	50	27	22	M130 x 2	30	12	16

1 kN = 224.8 Pounds Force.

### To order please specify:

- model number
- maximum stroke

Example:  
CDS 1.0 x 75

**PAD MOUNTED CYLINDERS TYPE CDSP**

MODEL	NOM. FORCE kN	S T R O K E						
		12.5	25	38	50	75	100	150
CDSP 0.3	3.3	•	•	•	•	•	•	
CDSP 0.5	5.0	•	•	•	•	•	•	
CDSP 1.0	10		•	•	•	•	•	
CDSP 2.5	25		•	•	•	•	•	
CDSP 3.5	35		•	•	•	•	•	•
CDSP 5.5	55		•	•	•	•	•	•
CDSP 10	100		•	•	•	•	•	•
CDSP 15	150		*	*	*	*	*	*
CDSP 20	200		*	*	*	*	*	*

\*CDSP 15 and CDSP 20 models are manufactured to order. Dimensional detail supplied on request.

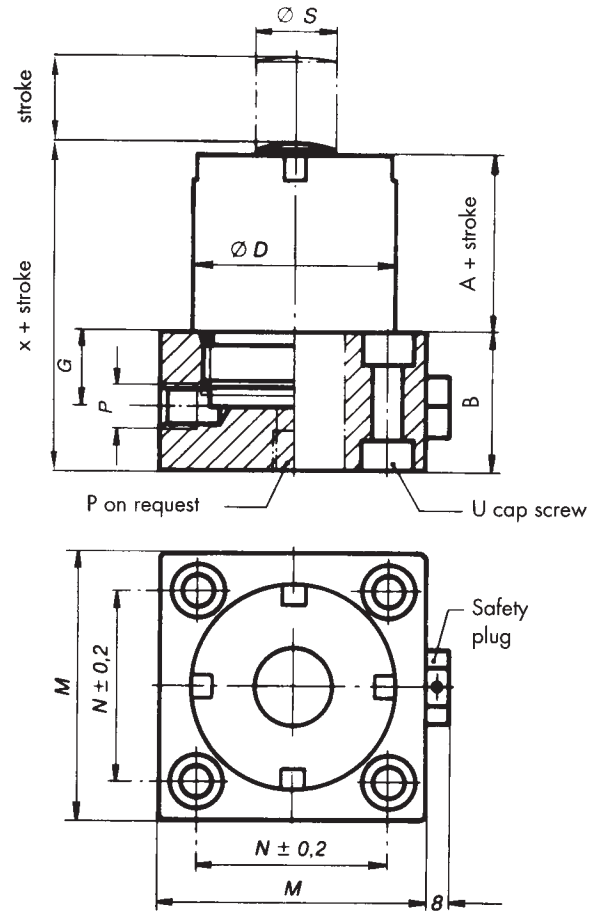

MODEL	A	X	B	ØD	ØS	G	P	M	N	U
CDSP 0.3	15.3	45.5	28.5	32	10	18	1/2".20	51	35	M8
CDSP 0.5	18.8	49.0	28.5	42	12	18	1/2".20	62	45	M8
CDSP 1.0	21.8	58.5	35	54	22	20	1/2".20	70	54	M8
CDSP 2.5	21.8	61.5	38	70	28	20	1/2".20	90	70	M8
CDSP 3.5	31.5	76.5	43	88	28	25	3/4".16	108	78	M10
CDSP 5.5	36.5	83.5	45	108	40	27	3/4".16	128	97	M12
CDSP 10	41.5	103.5	60	146	50	39	3/4".16	156	124	M16

1 kN = 224.8 Pounds Force.

**To order please specify:**

- model number
- maximum stroke
- thread "P" if required on plate bottom

**Example:**

CDSP 5.5 x 50 with thread on bottom

## LOW PROFILE CYLINDERS TYPE CDSN

MODEL	NOM. FORCE kN	S T R O K E						
		12.5	25	38	50	75	100	150
CDSN 0.3	3.3	•	•	•	•	•	•	
CDSN 0.5	5.0		•	•	•	•	•	
CDSN 1.0	10		•	•	•	•	•	•
CDSN 2.5	25		•	•	•	•	•	•
CDSN 3.5	35		•	•	•	•	•	•
CDSN 5.5	55		•	•	•	•	•	•
CDSN 10	100		•	•	•	•	•	•

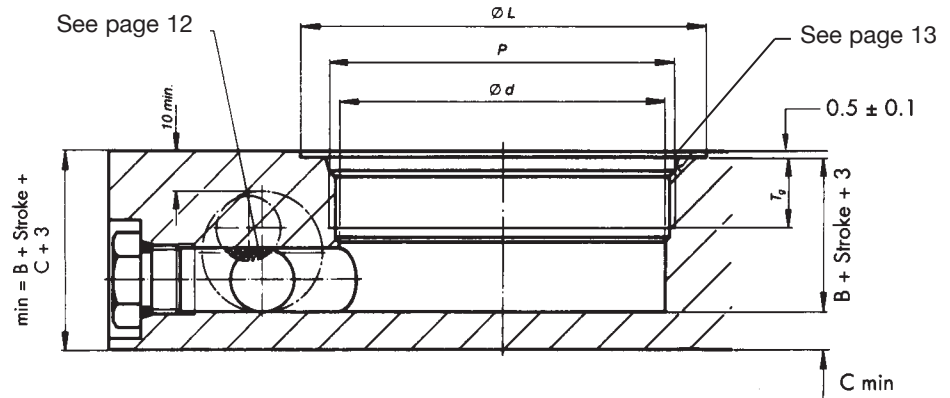
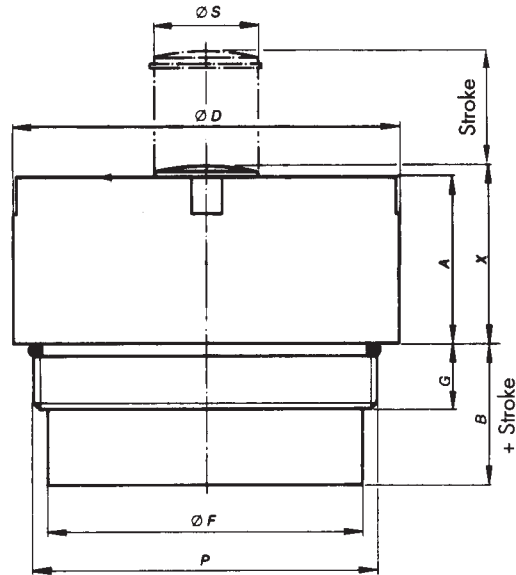

MODEL	A	B	X	ØD	Ød	ØF	ØL	ØS	G	P	Tg	C min
CDSN 0.3	18.3	13.0	20	32	24	23.5	44	10	15	M27 x 2	20	10
CDSN 0.5	40.5	-6.7	42	42	33	32.5	50	12	15	M36 x 2	20	10
CDSN 1.0	40.5	-3.2	42	54	44	42	65	22	15	M48 x 2	20	10
CDSN 2.5	40.5	-1.7	42	70	62	61	80	28	15	M64 x 2	20	10
CDSN 3.5	49.5	1.5	51.5	88	77	76	92	28	18	M80 x 2	23	10
CDSN 5.5	52.5	9.0	54.5	108	96	95	112	40	20	M100 x 2	25	13
CDSN 10	62.5	6.0	64.5	146	126	125	151	50	22	M130 x 2	30	16

1 kN = 224.8 Pounds Force.

**To order please specify:**

- model number
- maximum stroke

Example:

CDSN 2.5 x 100



**PANCAKE CYLINDERS TYPE CDSK**

MODEL	NOM. FORCE kN	S T R O K E			
		6	10	15	20
CDSK 1.0	10	•	•	•	•
CDSK 2.5	25	•	•	•	•
CDSK 3.5	35	•	•	•	•
CDSK 5.5	55	•	•	•	•

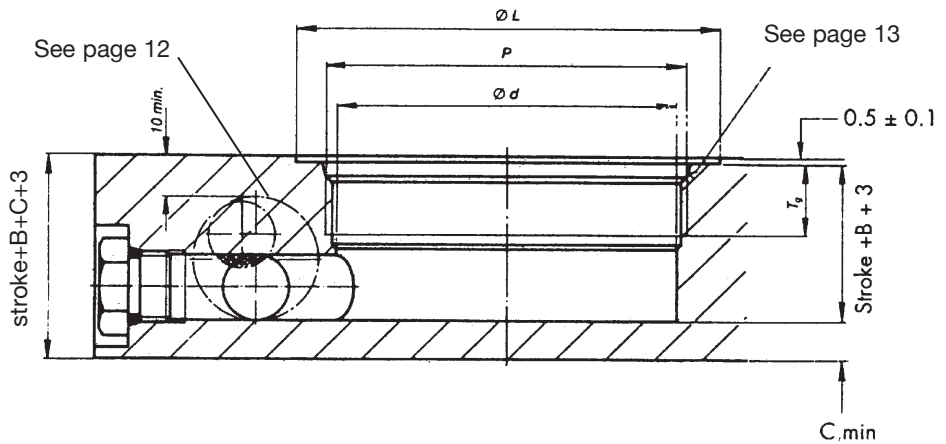
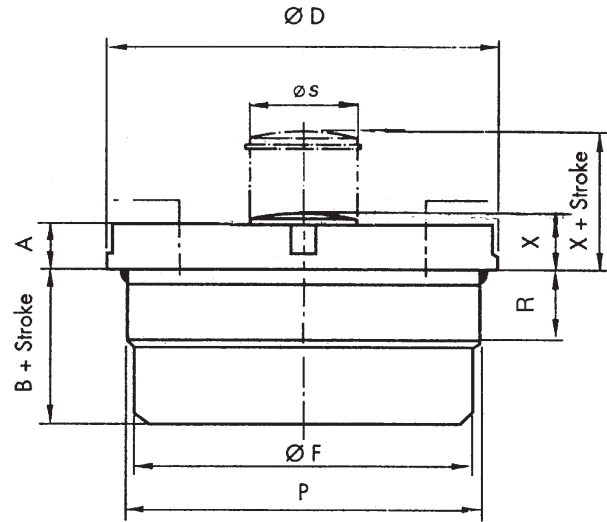

MODEL	A	B	X	ØD	Ød	ØF	ØL	ØS	R	P	Tg	C min
CDSK 1.0	10	22	11	54	44	42	65	18	18	M48 x 2	20	10
CDSK 2.5	10	24	12	70	62	61	80	28	17	M64 x 2	20	10
CDSK 3.5	14	31	16	88	77	75	92	28	19	M80 x 2	23	10
CDSK 5.5	14	31	16	108	96	95	112	40	19	M100 x 2	25	13

1 kN = 224.8 Pounds Force.

**To order please specify:**

- model number
- maximum stroke

Example:  
CDSK 2.5 x 10

## CYLINDERS TYPE CDSF 1, 2.5, 5.5

### Type CDSF

for screw in

Rupture plug BS 150/5

Boring for the oil and waste fallout

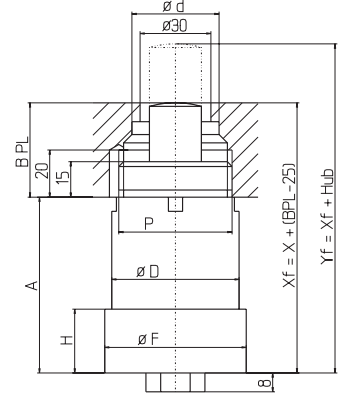
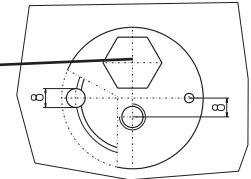

At all units CDSF 2,5 fill thread 1/2"-20 centre of the cylinder

Order No.	Area cm <sup>2</sup>	Force in kN (with 110 bar)	Stroke mm	A	Ø D	Ø d	Ø F/H	Ø P	Ø X <sub>f</sub>	Ø Y <sub>f</sub>
CDSF 1.0	25	77.5								
CDSF 1.0			38	90.5	54	44	60/30	M 4Bx2	(Bpl-25)	X <sub>f</sub> +Stroke
CDSF 1.0	9.61	10.57	50	102.5					X+(Bpl-25)	X <sub>f</sub> +Stroke
CDSF 1.0			75	127.5						
CDSF 2.5			25	77.5						
CDSF 2.5			38	90.5	70	60	79/30	M 64x2	(Bpl-25)	X <sub>f</sub> +Stroke
CDSF 2.5	22.39	25.18	50	102.5					X+(Bpl-25)	X <sub>f</sub> +Stroke
CDSF 2.5			75	127.5						
CDSF 5.5			25	106.5						
CDSF 5.5			38	119.5	108	98	118/4	M 100x2	(Bpl-25)	X <sub>f</sub> +Stroke
CDSF 5.5	50.24	55.26	50	131.5			5		X+(Bpl-25)	X <sub>f</sub> +Stroke
CDSF 5.5			75	176.5						

## MANIFOLD PLATE DESIGN AND ASSEMBLY

To ensure an air tight manifold plate, it is essential that the "O" ring seating of cylinder and port be free of any tool marks or scratches. A finely ground porting tool of the correct size should be used to achieve the required surface finish.

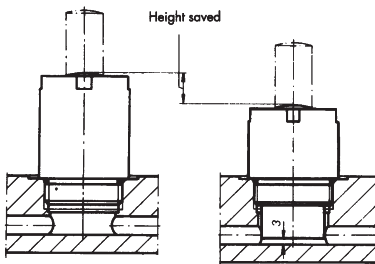

If space permits, the tool height can be reduced by using low profile or pancake cylinders (CDSN or CDSK).

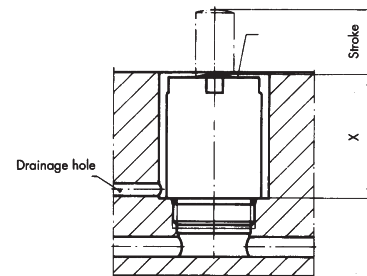

When cylinders are embedded in the manifold plate, a drainage hole must be drilled in the bottom of the pocket to prevent the accumulation of oil and other debris.

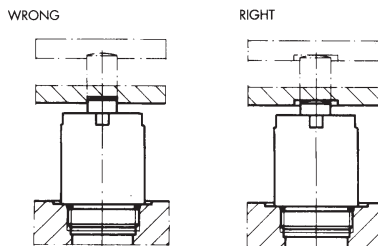

Any lateral clamping of the piston rod dramatically reduces the cylinder lifetime. The position rod must remain laterally free.

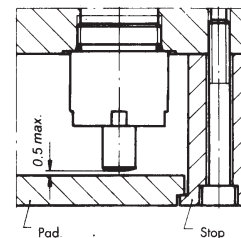

In hollow assemblies, the maximum clearance at top stroke between the pad and piston rod should be 0.5 mm. The pad should always be guided during the stroke.

**SPARE PARTS**

Gas cylinders are subject to wear according to the severity of application and working environment. Protection of the cylinder body and piston rod bearing surfaces against damage, as well as continuous lubrication, will significantly extend the cylinder's operating life.

Parts with scratched bearing surfaces should be replaced. Under normal circumstances maintenance consists merely of installing a new set of seals. Avoid cleaning disassembled parts with cloth rags and re-assemble under clean conditions.

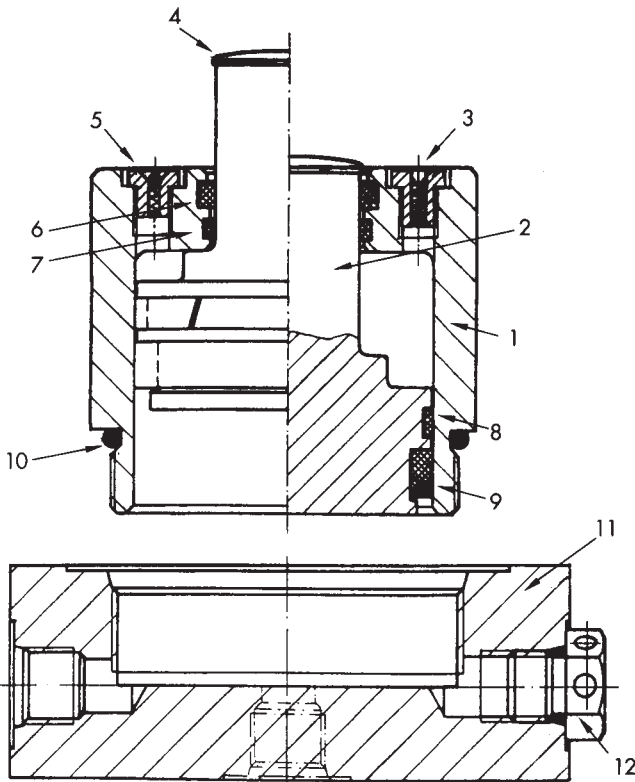

NUMBER	DESCRIPTION
1	Cylinder Body
2	Piston
3	Ventilation valve
4	Circlip
5	Oil fill valve
6	Wiper ring
7	Piston rod guide ring
8	Piston head guide ring
9	Piston seal
10	O-ring
11	Cylinder plate (CDSP only)
12	Safety plug (CDSP only)

**ITEMS 1-2**

Please specify cylinder type, nominal force, maximum stroke, and item number.

Example: CDS 1.0 x 75 Item 1

**ITEMS 3-12**

Please specify cylinder type, nominal force, and item number

Example: CDSP 2.5 Item 12

All seals should be replaced at the same time.

Example: CDS 5.5 Items 6-10

**MANIFOLD PLATE MACHINING DATA**

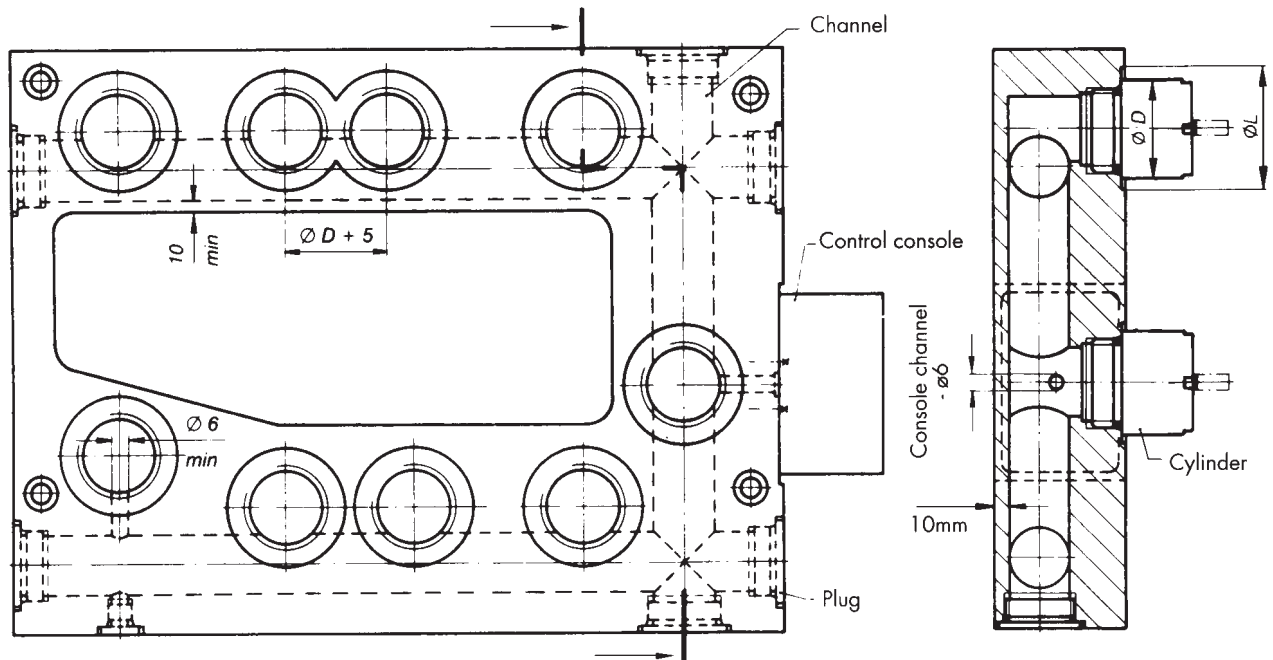

Fig. 12.1

- Manifold plates should be made exclusively of ultrasonically tested steel, never cast iron.
- Parts must not be welded to the manifold plate. Only threaded connections should be used.
- The area of intersection "B" (figure 12.2) should be at least 5% of the cross section of the largest channel, with a minimum area of 1.5 cm<sup>2</sup>. Channel diameter must be a minimum of 6 mm.
- Channels should not be machined as blind holes where debris may collect. (figure 12.3)
- All secondary machining in the manifold should have a minimum clearance of 10 mm from the channels.
- Minimum centre distance between adjacent cylinders should be equal to the cylinder outside diameter + 5 mm.

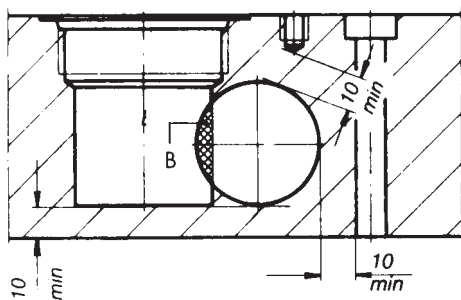

Fig. 12.2

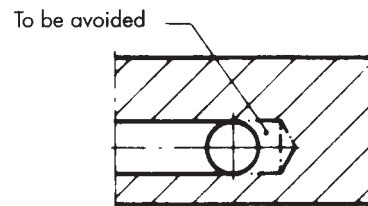
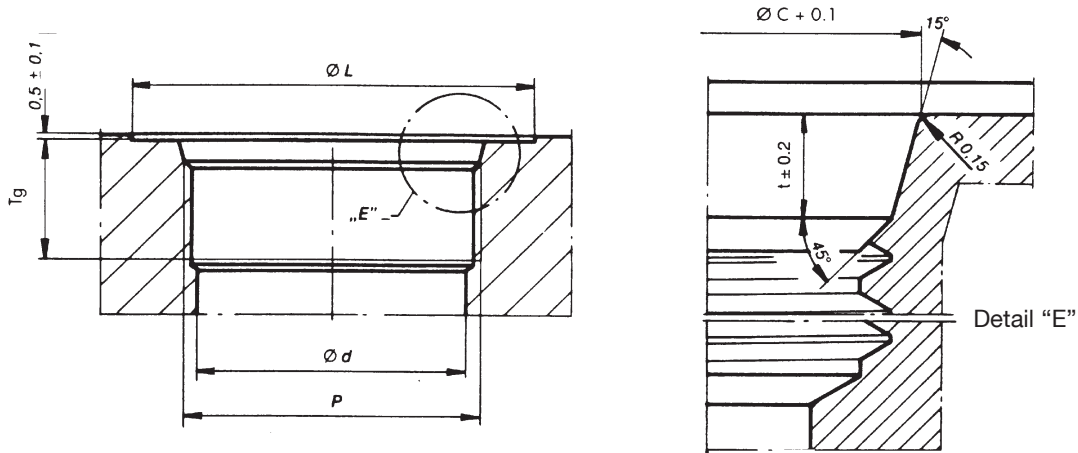

Fig. 12.3

**NOTES FOR MANUFACTURING THE THREAD AND SEAL ANGLES**



It's important, to enable the sealing of the system, that the shape for the o-ring is exact and clean, and that the surface pressure between cylinder and plate fits well. Make the sealing angle with the suitable profile-mill tool.

TYPE	PROFILE-MILL TOOL	THREAD	P	Ø C + 0.1	CO-BORING Ø d	LINEAR VOLUME cm³/cm	t±0.2	ØL	Tg
<b>CYLINDER</b>									
0.3	FS 27	GB 27	M 27 x 2	28.9	24	4.15	3.5	44	20
0.5	FS 36	GB 36	M 36 x 2	37.9	33	8.55	3.5	50	20
1.0	FS 48	GB 48	M 48 x 2	49.9	44	15.20	3.5	65	20
2.5	FS 64	GB 64	M 64 x 2	65.9	62	30.19	3.5	80	20
3.5	FS 80	GB 80	M 80 x 2	83.2	77	46.57	4.4	92	23
5.5	FS 100	GB 100	M 100 x 2	103.0	96	72.38	4.4	112	25
10	FS 130	GB 130	M 130 x 2	133.2	126	124.69	4.4	151	30
<b>PORT PLUG</b>									
V2 - 36	FS 36	GB 36	M 36 x 2	37.9	33	8.55	3.5	50	20
V2 - 42	FS 42	GB 42	M 42 x 2	43.9	39	11.95	3.5	58	20
V2 - 48	FS 48	GB 48	M 48 x 2	49.9	45	15.90	3.5	65	20
V2 - 64	FS 64	GB 64	M 64 x 2	65.9	60	28.27	3.5	80	20
V2 - 80	FS 80	GB 80	M 80 x 2	83.2	76	45.36	4.4	92	25
V2 - 100	FS 100	GB 100	M 100 x 2	103.2	96	72.38	4.4	112	25
V2 - 130	FS 130	GB 130	M 130 x 2	133.2	126	124.69	4.4	151	30
<b>EXTERNAL</b>									
NP 77.5	TCT 5	GB 1/2" .20	1/2" .20	14.0	10	-	2.5	25	15
NP 77.8	TCT 8	GB 3/4" .16	3/4" .16	20.6	16	-	2.7	34	15

**SMALL TANKS TYPE NP - T**

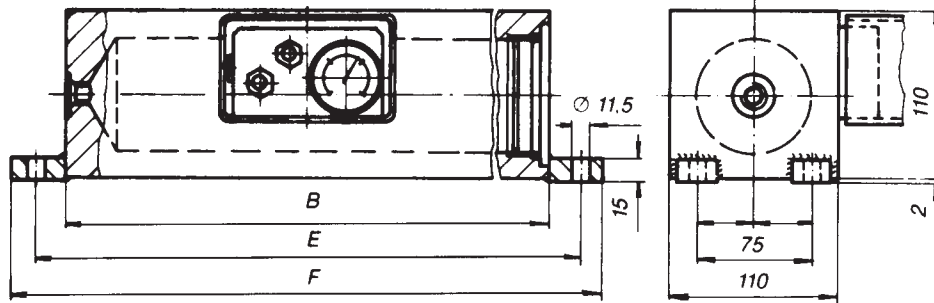

MODEL	VOLUME LITRES	B	E	F
NP-T 102	0.52	160	200	230
NP-T 103	1.15	300	340	370

When ordering please furnish a sketch showing the location of the safety plug and tapped connecting holes.

**THREADED TANKS TYPE TDN-R (UP TO 20 LITRES)**

External tanks are required a) when the manifold plate volume is not sufficient to limit the pressure increase to 10%, or b) when pad-mounted cylinders are used. Threaded tanks are quickly produced at a competitive price, and they provide maximum operational safety.

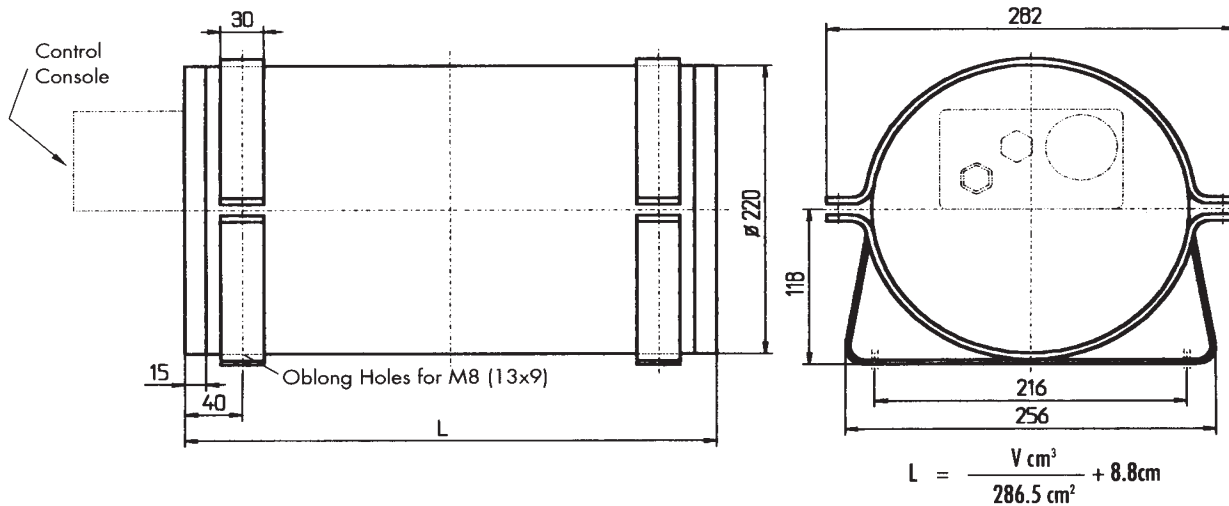

The connection fittings and the control unit can only be assembled on the face of the end cap. For each 5 litres of gas volume one 1/2" - 20 BS 150 safety plug must be used. If the control console is mounted to the tank, its internal safety plug can be counted as one plug.

**To order please specify:**

- model number
- volume in litres

**Example:**

TDN-R 10

## CUSTOM WELDED TANKS TYPE NPT (UP TO 100 LITRES)

These tanks should be selected when a larger gas volume or smaller tank size is required. The arrangement of service ports and tapped holes shown below is only an example.

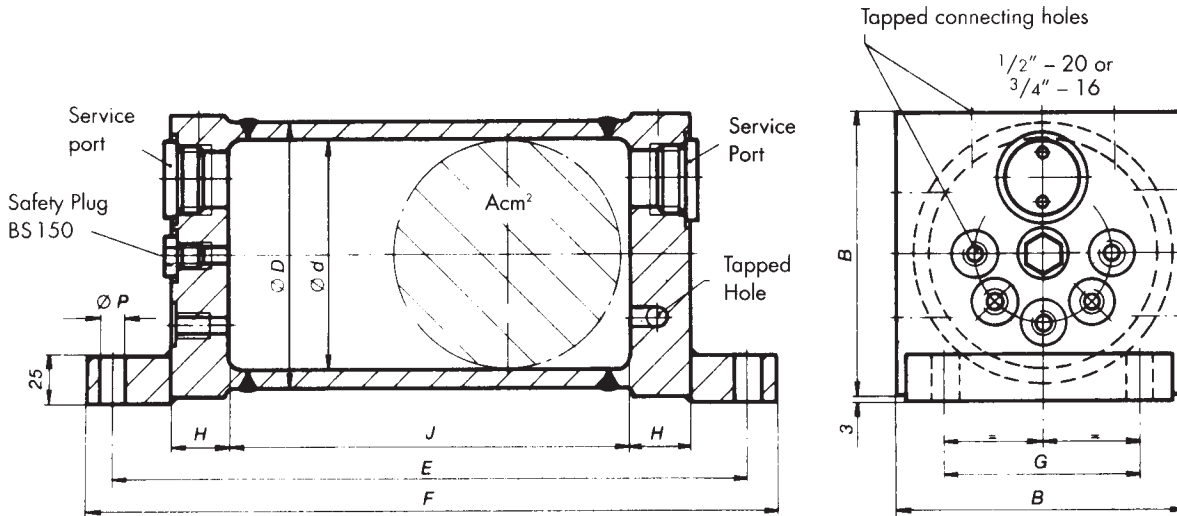

MODEL	A cm <sup>2</sup>	B	H	ØD	Ød	E	F	G	ØP
NPT 5	108.8	150	40	139.7	117.7	J+140	J+170	100	14
NPT 8	285.0	225	40	219.1	190.7	J+160	J+200	180	18
NPT 10	655.2	350	45	323.9	288.9	J+170	J+210	280	18

$$J = \frac{\text{Tank Volume}}{A}$$

As with threaded tanks, one 1/2" - 20 BS 150 safety plug must be used for each 5 litres of gas volume. The maximum number of tapped holes possible per side is indicated in the following sketch and table.

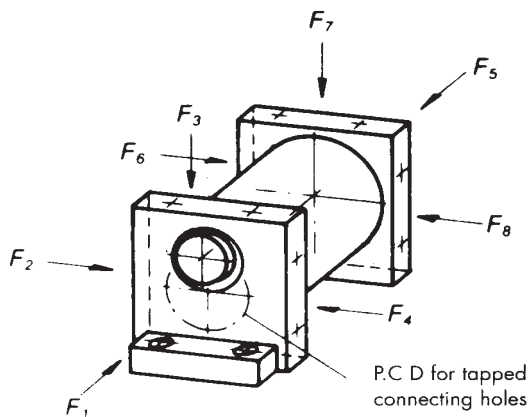

### CONNECTIONS

MODEL	NPT 5		NPT 8		NPT 10	
	1/2" - 20	3/4" - 16	1/2" - 20	3/4" - 16	1/2" - 20	3/4" - 16
F1	8	5	9	9	20	20
F2, 3, 4	2	•	2	2	5	5
F5	8	5	9	9	20	20
F6, 7, 8	2	•	2	2	5	5

#### To order please specify:

- model number and required volume
- number, size and position of connections

#### Example:

- (1) NPT 8 - 10 Litres
- (2) 1/2" - 20 at F<sub>1</sub>
- (1) 3/4" - 16 at F<sub>3</sub>

## CONTROL CONSOLES

**MODEL KA 110.01 - 80** for installation on manifold plates 80 mm and thicker, and on external tanks.

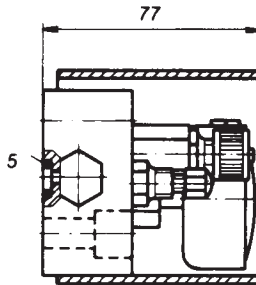
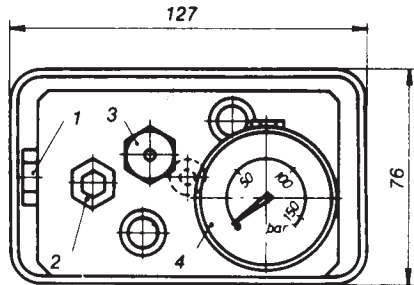

location of mounting holes and fill connection

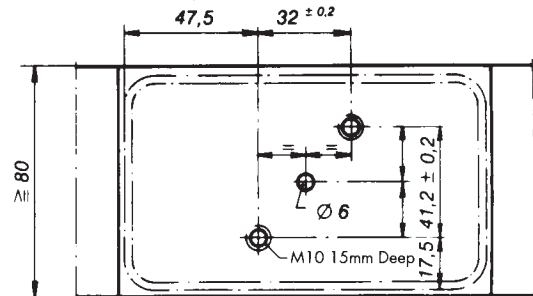

**MODEL KA 110.01 - 32** for installation on manifold plates 32 mm and thicker

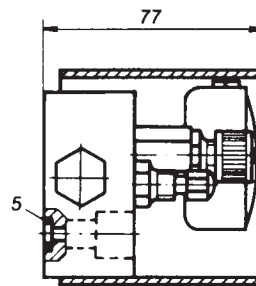
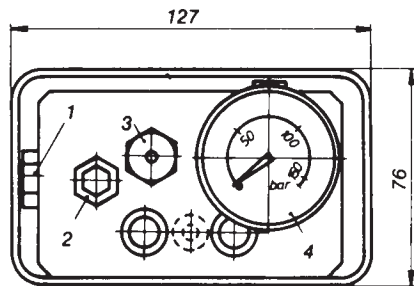

location of mounting holes and fill connection

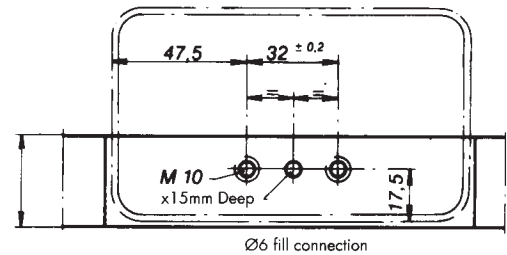

**MODEL KA 110.01** for installations where the control console cannot be mounted on the manifold plate or on the external tank. It can also be used with Type CDSP pad - mounted cylinders

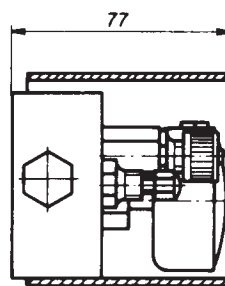
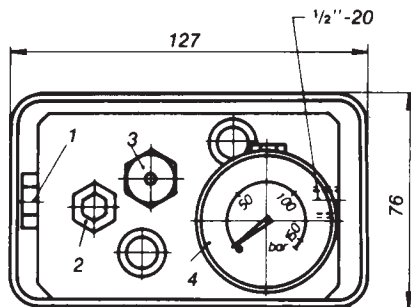

location of mounting holes

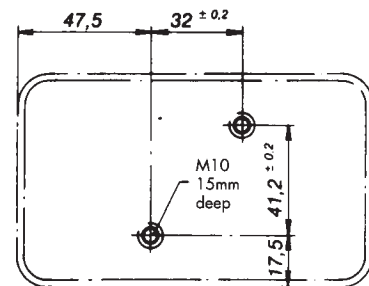

- |                   |                |                  |
|-------------------|----------------|------------------|
| 1. Safety Plug    | 2. Inlet valve | 3. Exhaust valve |
| 4. Pressure gauge | 5. "O" ring    |                  |



## SPARE PARTS FOR CONTROL CONSOLES

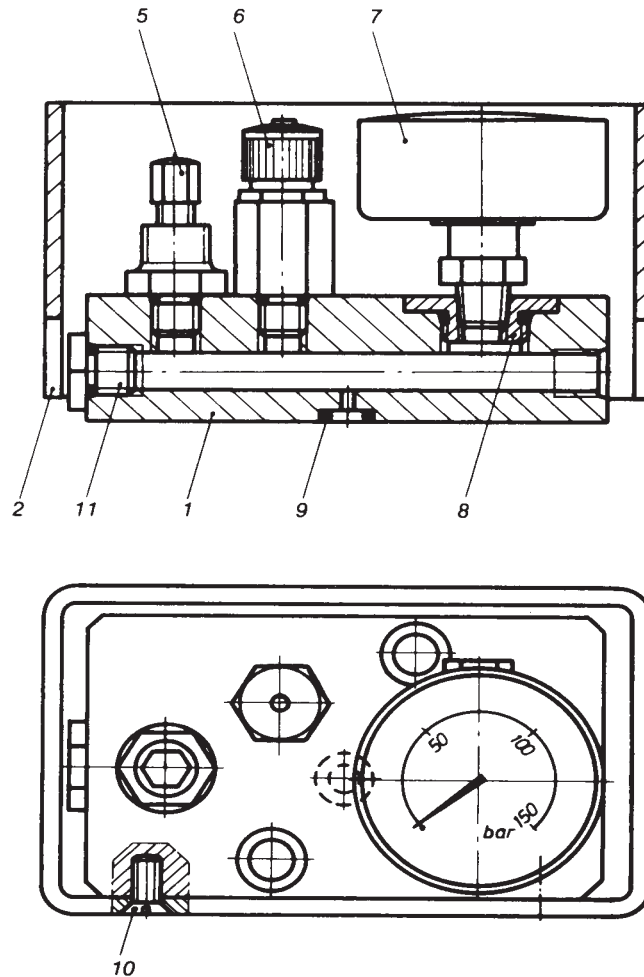

### CONSOLE MODELS

MODEL	DESCRIPTION	KA-110.01	KA-110.01-32	KA-110.01-80
1	Console Body	KA - 01.00	KA - 01.32	KA - 01.80
2	Cover	KA - 02.00	KA - 02.00	KA - 02.00
5	Inlet valve - screw fitting type	KA - 05.00	KA - 05.00	KA - 05.00
6	Exhaust Valve	KA - 06.00	KA - 06.00	KA - 06.00
7	Pressure gauge	KA - 07.00	KA - 07.00	KA - 07.00
8	Adaptor	KA - 08.00	KA - 08.00	KA - 08.00
9	O-ring	-	KA - 09.00	KA - 09.00
10	Screws (2 pieces)	M6 x 10	M6 x 10	M6 x 10
11	Safety plug	BS 150/5	BS 150/5	BS 150/5

## VOLUME CALCULATION

Ideally, the system's pressure should not increase more than 10%. This design consideration plus the volume swept by the cylinders during the working cycle determine the gas volume required in the manifold channels or reservoir tank.

Formulas

1.  $V_{cyl} = n \times A_{cyl} \times \text{stroke}$

2.  $V_1 = \frac{V_{cyl} (100\%) + p}{p}$

3.  $V_2 = V_1 - V_{cyl}$

Example: (10) CDS 2.5 x 50

$V_{cyl} = 10 \times 22.89 \text{ cm}^2 \times 5\text{cm}$   
 $= 1144.5 \text{ cm}^3$

$V_1 = \frac{1144.5 \text{ cm}^3 \times (100\% + 10\%)}{10\%}$   
 $= 12,589.5 \text{ cm}^3 = 12.59 \text{ Litres}$

$V_2 = 12,589.5 \text{ cm}^3 - 1144.5 \text{ cm}^3$   
 $= 11,445 \text{ cm}^3 = 11.45 \text{ Litres}$

In designing the manifold plate the largest possible channel diameter should be chosen (see page 14-15)

4.  $L_B = \frac{V_2}{A_B}$

Example: channel Ø 40 mm

$L_B = \frac{11,445 \text{ cm}^3}{12.57 \text{ cm}^2}$   
 $= 910.5 \text{ cm}$

If the gas volume in the manifold is insufficient, or if pad-mounted cylinders are used, an external tank is required (see pages 12-13)

If the initial volume is known, the pressure increase can be calculated as follows:

5.  $p_1 V_1 = p_2 V_2$

6.  $p = \frac{(p_2 - p_1) \times 100\%}{p_2}$

- $V_1$  = initial volume at top stroke
- $V_2$  = volume at bottom stroke = Manifold/tank volume
- $V_{cyl}$  = volume swept by the cylinders
- $p_1$  = pressure at top stroke
- $p_2$  = pressure at bottom stroke
- $p$  = pressure increase in %
- $n$  = number of cylinders
- $A_{cyl}$  = piston area
- $L_B$  = channel length
- $A_B$  = channel cross section

MODEL	$A_{cyl} \text{ cm}^2$	NORMAL FORCE kN	OUTSIDE DIAMETER mm	PISTON ROD DIAM mm	STROKE mm
0.3	3.14	3.4	32	10	12.5-100
0.5	4.90	5	42	12	12.5-100
1.0	9.61	10	54	22	25 - 150
2.5	22.89	25	70	28	25 - 200
3.5	33.16	35	88	28	25 - 250
5.5	50.24	55	108	40	25 - 250
10	94.98	104	146	50	25 - 300
15	132.66	150	168	60	25 - 300

Channel Ø mm	Area $A_B$ in $\text{cm}^2$	Channel Ø mm	Area $A_B$ in $\text{cm}^2$
10	0.79	45	15.90
12	1.13	60	28.27
16	2.01	75	44.17
22	3.80	90	63.62
25	4.91	100	78.54
33	8.55	110	95.03
40	12.57	120	113.10

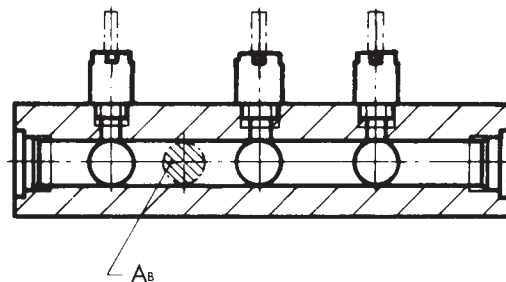

## PORT PLUGS AND SAFETY PLUGS

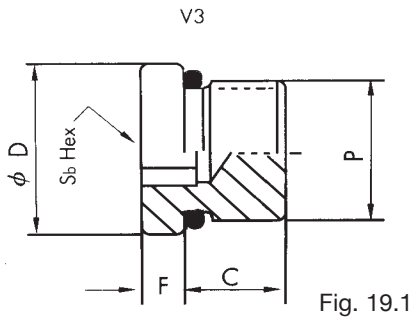

Fig. 19.1

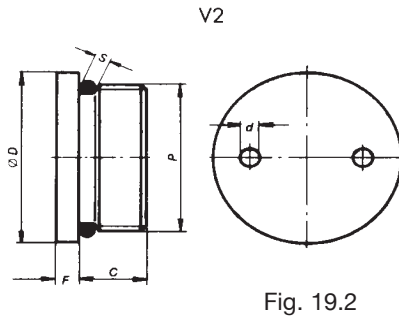

Fig. 19.2

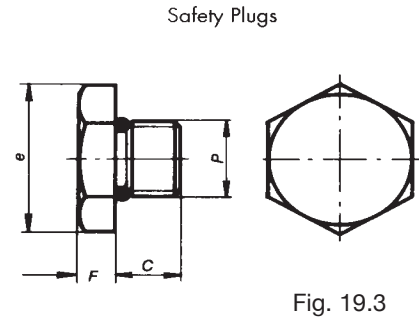

Fig. 19.3

**IMPORTANT:** Do not weld the plugs to the plates. Do not use tapered plugs.

TYP	P THREAD	C	F	Ød	ØD		e	O-RING ØDxØS	FOR MAX. DRILLED DIAM.
PORT PLUGS									
NP - 77-5	1/2" - 20	11	8	-	SW17	-	-	-	10
NP - 77-8	3/4" - 16	11	9	-	SW22	-	-	-	16
V3 - 14	M 14 x 1.5	12	5	-	19	-	-	-	12
V3 - 20	M 20 x 1.5	14	5	-	26	-	-	-	18
V3 - 27	M 27 x 2	16	5	-	32	-	-	-	24
V2 - 36	M 36 x 2	15	5	4.1	42	-	-	32 x 3	33
V2 - 42	M 42 x 2	15	5	4.1	48	-	-	38 x 3	39
V2 - 48	M 48 x 2	15	5	4.1	54	-	-	44 x 3	45
V2 - 64	M 64 x 2	15	5	4.1	70	-	-	60 x 3	60
V2 - 80	M 80 x 2	20	10	6.1	88	-	-	76 x 4	76
V2 - 100	M 100 x 2	20	10	6.1	108	-	-	96 x 4	96
V2 - 130	M 130 x 2	25	10	8.1	145	-	-	126 x 4	126

### SAFETY PLUGS

BS - 150/5	1/2" - 20	11	8	-	SW17	-	19.5	9 x 2	10
BS - 170/5	1/2" - 20	11	8	-	SW17	-	19.5	9 x 2	10
BS - 250/5	1/2" - 20	11	8	-	SW17	-	19.5	9 x 2	10
BS - 150/11	M20 x 1.5	15	10	-	SW19	-	27.0	17 x 2.5	16

Drilled diameters larger than 126 mm should be capped with a plate and "O" rings (see fig. 19.4) The number, grade, and preload of the screws must be specified for a pressure of 165 bars (the maximum pressure of the safety plugs), a safety factor of 1.5, and a cyclic fatigue loading.

Fig. 19.4

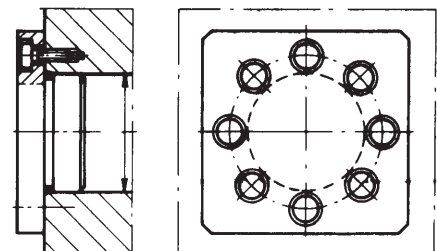

**FITTINGS AND HOSES**

**STRAIGHT FITTING:**  
Model NP 1000 - 5

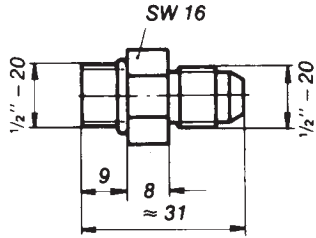

**45° ELBOW FITTING:**  
Model NP 4500 - 5

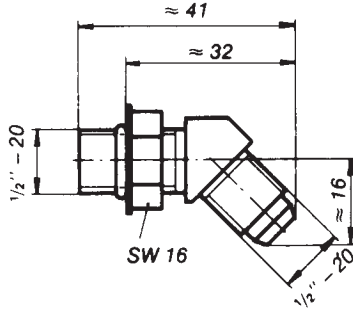

**90° ELBOW FITTING:**  
Model NP 2000 - 5

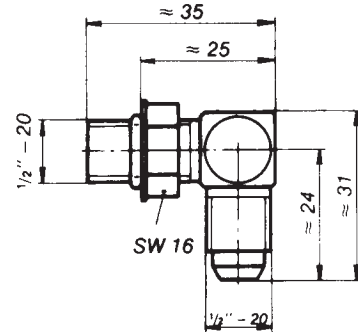

**BRANCH TEE:**  
Model NP 3000 - 5

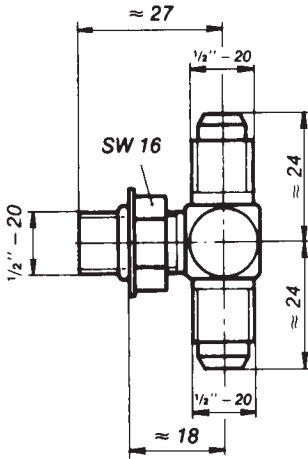

**PORT PLUG:**  
Model NP 77 - 5

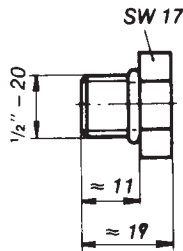

**HOSE SWIVEL FITTING:**  
Model NPG - 5

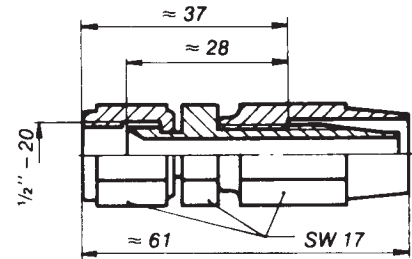

**HOSE CLAMP:**  
Model NPC - 5

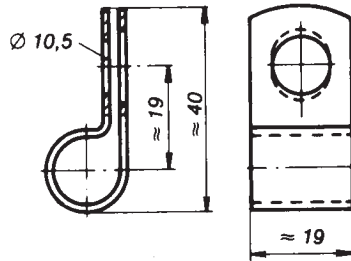

**HOSE GUARD:**  
Model NPS - 5



**HOSE:** Model NP 121 - 5 x L1

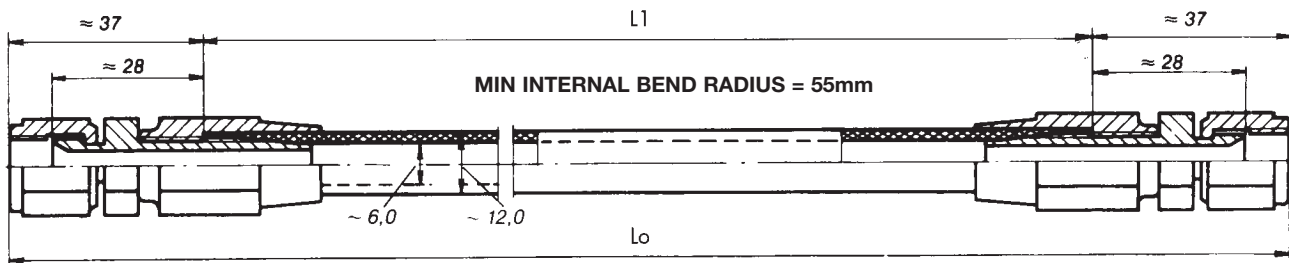

To order complete hose specify : NP 121-5 x Lo (2) NPG-5 assembled. When Lo is less than 300 mm the hose must be cut by customer to exact length required. One swivel fitting is delivered separately.

**FITTINGS AND HOSES**

STRAIGHT FITTING:  
Model NP 1000 - 8

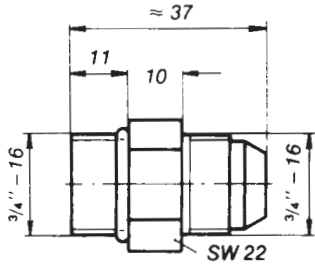

45° ELBOW FITTING:  
Model NP 4500 - 8

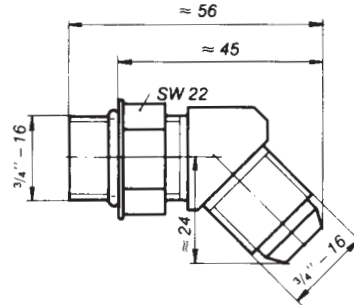

90° ELBOW FITTING:  
Model NP 2000 - 8

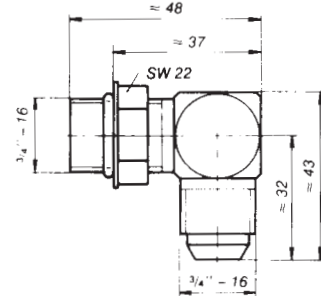

BRANCH TEE:  
Model NP 3000 - 8

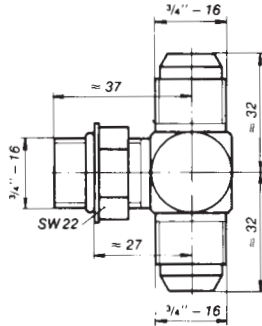

PORT PLUG:  
Model NP 77 - 8

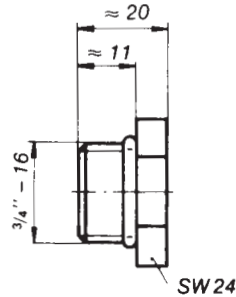

HOSE SWIVEL FITTING:  
Model NPG - 8

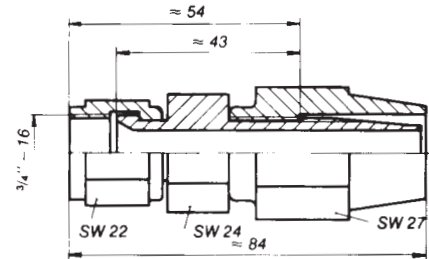

HOSE CLAMP:  
Model NPC - 8

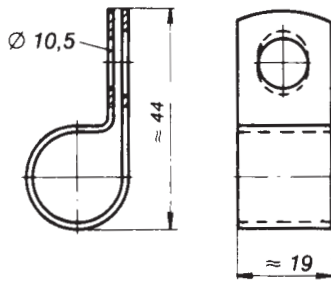

HOSE GUARD:  
Model NPS - 8



HOSE : Model NP 121 - 8 x L1

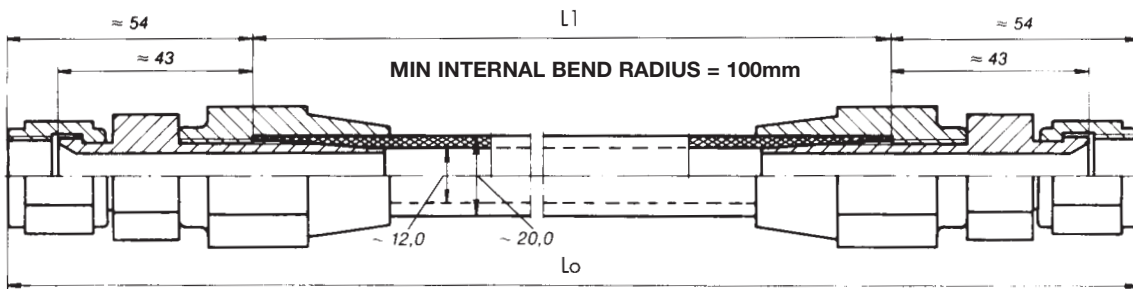

To order complete hose specify : NP 121-8 x Lo (2) NPG-8 assembled. When Lo is less than 400 mm the hose must be cut by customer to exact length required. One swivel fitting is delivered separately.

## BOTTLE FILL UNIT NPA 110.01

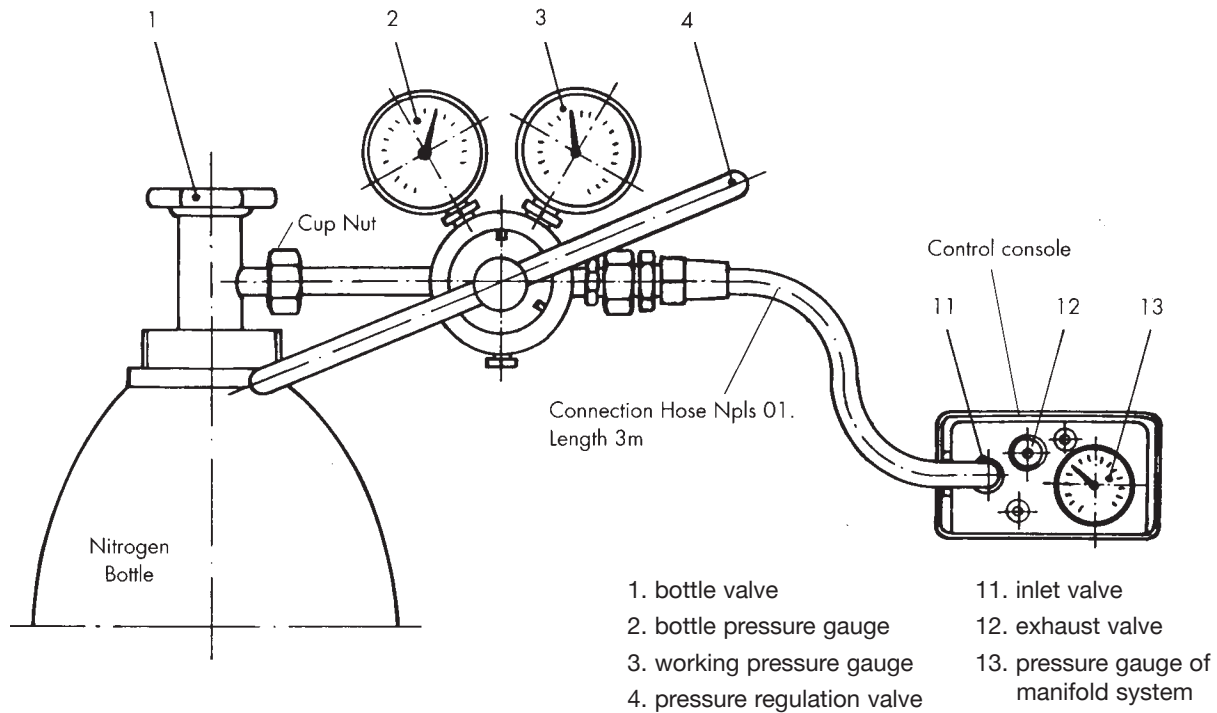

### Filling instructions:

1. Connect the bottle fill unit with the cup nut on the nitrogen bottle.
2. Connect the bottle fill unit with the hose at the control console (the hose must be ordered separately).
3. Close the exhaust valve (12).
4. Open bottle valve (1) carefully. The bottle pressure gauge will show the internal pressure of the bottle.
5. Open or close the pressure regulation valve (4) so that the working pressure gauge (3) shows the required pressure.
6. The manifold pressure will build slowly, giving you time to adjust the regulation valve to the correct pressure. When the manifold pressure equals the working pressure the system is filled.
7. Close bottle valve (1).
8. Disconnect hose from the inlet valve.

# Manifold Systems Hotline Worksheet

Designing the correct manifold is as easy as 1, 2, 3

## 1. Information

Name: \_\_\_\_\_  
 Company Name: \_\_\_\_\_  
 Address: \_\_\_\_\_  
 Phone: \_\_\_\_\_ Fax: \_\_\_\_\_  
 Die/job number: \_\_\_\_\_  
 Type of work performed, example draw, form, ...

Advise quantity & size of and other holes (tapped, clearance, dowel pin, etc.)  
 quantity \_\_\_\_\_  
 size \_\_\_\_\_

Advise quantity and description of any other special machining (milled pockets, milled flanges, keyways, chamfers, drain slots, etc.)

## 2. Describe Your System

### Plate information

Quantity of plates: \_\_\_\_\_  
 Finished plate size: \_\_\_\_\_ x \_\_\_\_\_ x \_\_\_\_\_

Describe the shape of the plate:  
 burned to template (includes control panel recess)  
 no special burn

What is the finished thickness tolerance, if shown:  
 \_\_\_\_\_

Describe the volume hole drilling

diameter	length	quantity

How many finish-milled edges ?  
 \_\_\_\_\_ (minimum 2 required)

Quantity & size of mounting holes (drill & C-bore)  
 quantity \_\_\_\_\_  
 size \_\_\_\_\_

Quantity & size of handling holes:  
 quantity \_\_\_\_\_  
 size \_\_\_\_\_

Plate weight (lbs.)	Handling Hole (min. 2 required)
0 - 2,000	5/8" - 11
2,001 - 3,500	5/8" - 10
3,501 - 5,000	1" - 8
5,001 - 7,500	1 1/4" - 7
7,501 - 12,500	1 1/2" - 6

### Cylinders

Advise quantity and type of cylinders:

qty	model	stroke	work strike	"Y" Dim., if special

What is the pressure rise? \_\_\_\_\_

Advise quantity and type of plugs:

quantity	size	quantity	size

### Control Panel

What style of control panel  
 RT-110.01-80  
 RT-110.01-32  
 RT-110.01-01

Is the control panel mounted:  
 recessed  
 flush mounted  
 remote

### Misc

List the quantity and description of any other component (hose, fittings, tanks, etc.)

## 3. Fax this worksheet to:

**READY TECHNOLOGY, INC.**  
**FAX: (937) 866-7226**  
 333 Progress Road • Dayton, OH 45449  
 (800) 543-4355 • (937) 866-7200

READY



## The Innovator of Our Industry<sup>SM</sup>

Our factories and offices:

U.S.A. • U.K. • France • Belgium • Germany • Sweden • Netherlands • India • Singapore

### READY TECHNOLOGY, INC.

333 Progress Rd. • Dayton, OH 45449  
(800) 543-4355 • (937) 866-7200 • fax (937) 866-7226

[www.readytechnology.com](http://www.readytechnology.com)

© 2013 READY Technology, Inc.  
CATALOG # 0313