

READY DESIGN-TITE® BE Series Extra Compact Nitrogen Gas (N₂) Springs

Every BE Extra Compact gas spring combines the convenience of a self-contained gas spring with the increased on-contact force and shorter body height of a bore seal cylinder.

Body Diameter: 15mm to 75mm.
Open Force: 65 lbs to 45,000 lbs.
Closed Force: 100 lbs to 69,500 lbs



MODEL	ØBody mm	Strokes mm	Fo daN		 ACTIVE SAFETY			VDI STANDARD
BE-90	15	7 - 80	90	✓	✓		✓	
BE-170	19	7 - 125	170	✓	✓		✓	✓
BE-275V	25	7 - 125	275	✓	✓		✓	
BE-350	32	10 - 125	350	✓	✓	✓	✓	✓
BE-500	38	10 - 125	470	✓	✓	✓	✓	✓
BE-750	45	10 - 125	740	✓	✓	✓	✓	✓
BE-925	50	13 - 125	920	✓	✓	✓	✓	✓
BE-1500	63	13 - 125	1500	✓	✓	✓	✓	✓
BE-2400	75	16 - 125	2400	✓	✓	✓	✓	✓
BE-4200	95	16 - 125	4200	✓	✓	✓	✓	✓
BE-6600	120	16 - 125	6600	✓	✓	✓	✓	✓
BE-9500	150	16 - 125	9500	✓	✓	✓	✓	✓
BE-20000	195	16 - 125	20000			✓		

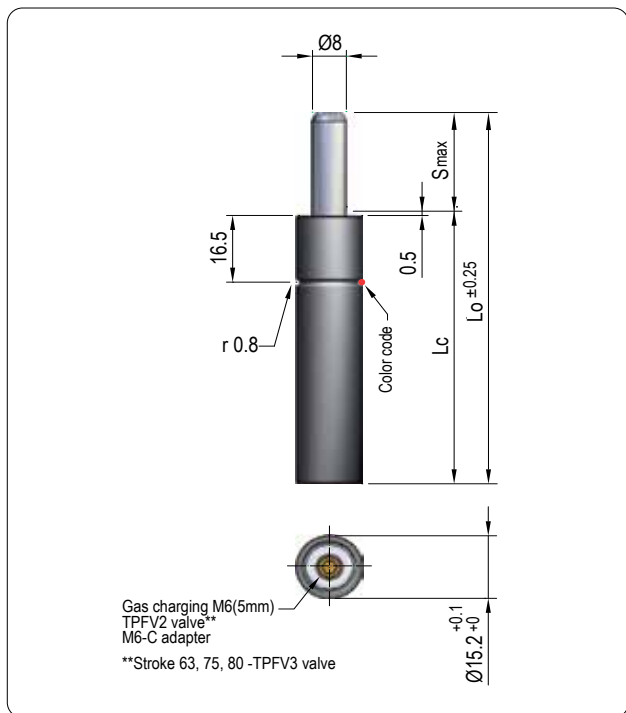

Pressure medium	Nitrogen Gas (N ₂)
Max. charging pressure	175 Bar
Min. charging pressure	50 Bar
Rod seal area	0,50 cm ²
Operating temperature	0°C - 80°C
Force increase by temperature	0,33 %/°C
Max. stem speed	0,8 m/s
Maintenance kit	Kit M15



VDI SAFETY



RE-8-15

Maximum strokes / minute (at 20°C)

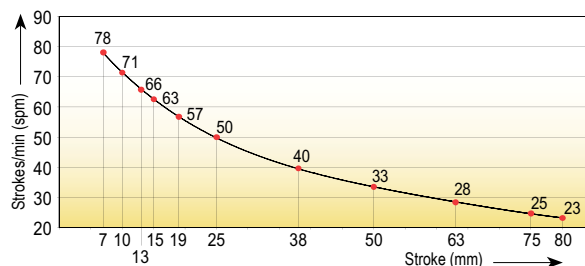

MODEL	Smax mm	Lo mm	Lc mm	V I	Kg
BE-90x7	7	56	49	0,001	0,07
BE-90x10	10	62	52	0,002	0,07
BE-90x13	13	68	55	0,002	0,08
BE-90x15	15	72	57	0,002	0,08
BE-90x19	19	80	61	0,003	0,09
BE-90x25	25	92	67	0,003	0,09
BE-90x38	38	118	80	0,005	0,10
BE-90x50	50	142	92	0,006	0,11
BE-90x63	63	172	109	0,008	0,12
BE-90x75	75	195	120	0,009	0,14
BE-90x80	80	205	125	0,010	0,15

Color code	Fo daN	Fc daN	P Bar
GRN (Green)	30 (±5)	≈ 48	60
BLU (Blue)	50 (±5)	≈ 80	100
RED (Red)	70 (±10)	≈ 112	140
YEL (Yellow)	90 (±10)	≈ 140	175
(Other forces)	25 - 90	≈ 40 - 140	50 - 175

The black color code denotes a different pressure from that which the customer could choose when ordering between the minimum charging pressure (50Bar) and the maximum charging pressure (175Bar). If not otherwise specified, the gas spring will be supplied in the yellow code version.

How to order

BE-90 x 50 YEL

Model

Stroke

Color code

Force/stroke ratio

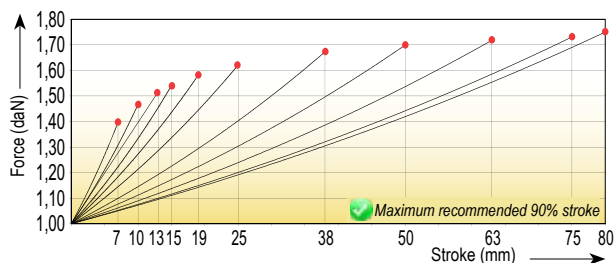

Initial force/charging pressure ratio

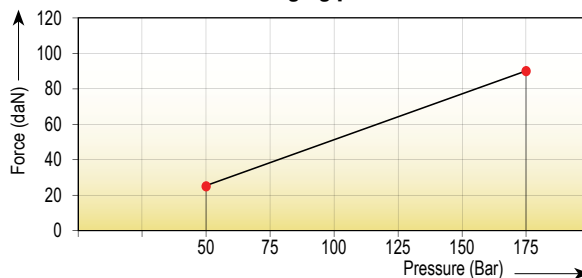

Assembly possibilities



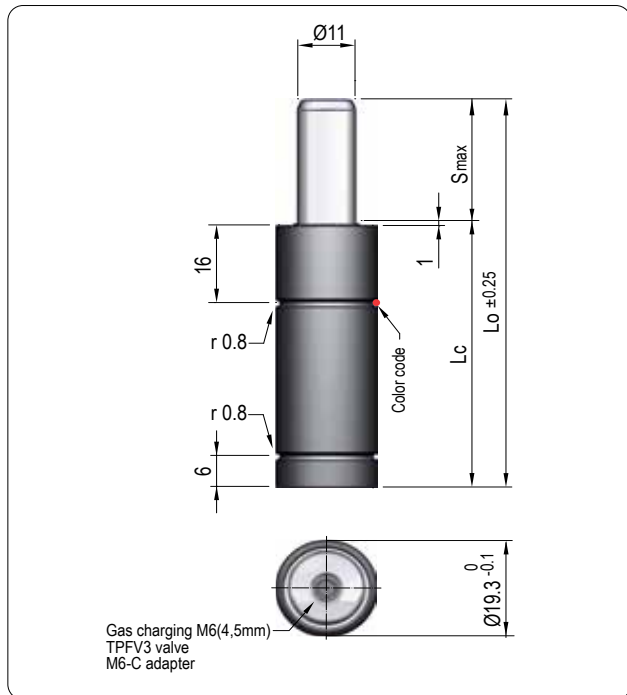

Pressure medium	Nitrogen Gas (N₂)
Max. charging pressure	175 Bar
Min. charging pressure	25 Bar
Rod seal area	0,95 cm²
Operating temperature	0°C - 80°C
Force increase by temperature	0,33 %/°C
Max. stem speed	1,6 m/s
Maintenance kit	Kit M19V1



Maximum strokes / minute (at 20°C)

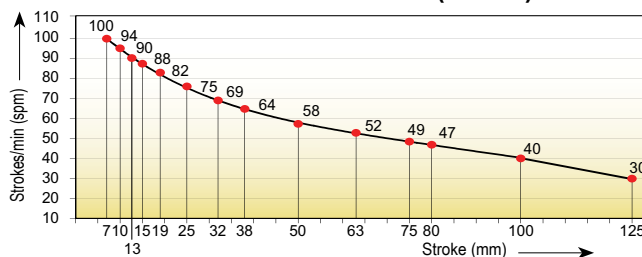

MODEL	Smax mm	Lo mm	Lc mm	V l	Kg
BE-170x7	7	44	37	0,002	0,07
BE-170x10	10	50	40	0,002	0,07
BE-170x13	13	56	43	0,003	0,08
BE-170x15	15	60	45	0,004	0,08
BE-170x19	19	68	49	0,005	0,09
BE-170x25	25	80	55	0,006	0,09
BE-170x32	32	94	62	0,007	0,10
BE-170x38	38	106	68	0,008	0,11
BE-170x50	50	130	80	0,011	0,12
BE-170x63	63	156	93	0,014	0,13
BE-170x75	75	185	110	0,017	0,13
BE-170x80	80	195	115	0,018	0,14
BE-170x100	100	235	135	0,022	0,15
BE-170x125	125	285	160	0,027	0,16

Color code	Fo daN	Fc daN	P Bar
GRN (Green)	60 (±5)	≈ 100	63
BLU (Blue)	90 (±5)	≈ 150	95
RED (Red)	120 (±10)	≈ 200	125
YEL (Yellow)	170 (±10)	≈ 280	175
(Other forces)	24 - 170	≈ 40 - 280	25 - 175

The black color code denotes a different pressure from that which the customer could choose when ordering between the minimum charging pressure (25sBar) and the maximum charging pressure (175Bar). If not otherwise specified, the gas spring will be supplied in the yellow code version.

How to order

BE-170 x **75** **GRN**

Model Stroke Color code

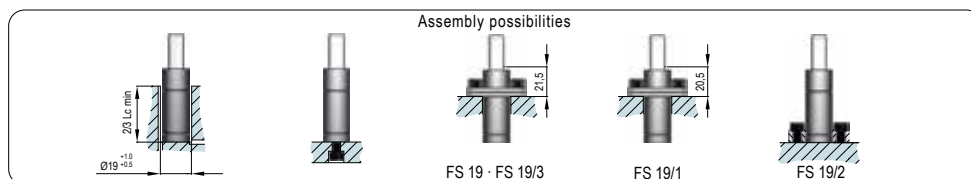
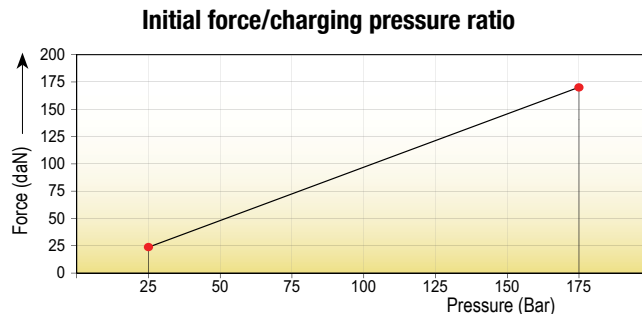
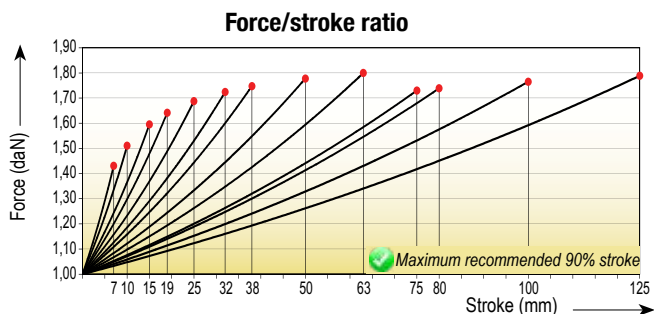

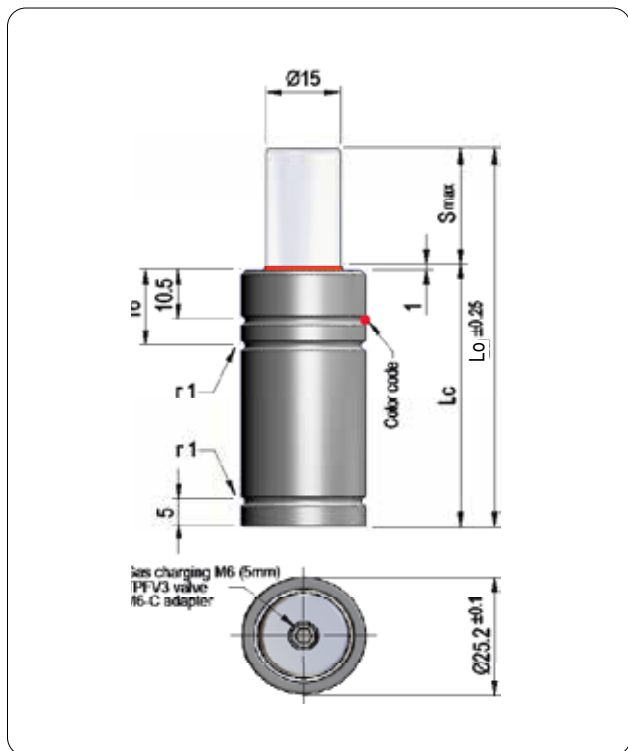

Pressure medium	Nitrogen Gas (N ₂)
Max. charging pressure	180 Bar
Min. charging pressure	30 Bar
Rod seal area	1,77 cm ²
Operating temperature	0°C - 80°C
Force increase by temperature	0,33 %/°C
Max. stem speed	1,6 m/s
Maintenance kit	Kit MV25



VDI SAFETY



Maximum strokes / minute (at 20°C)

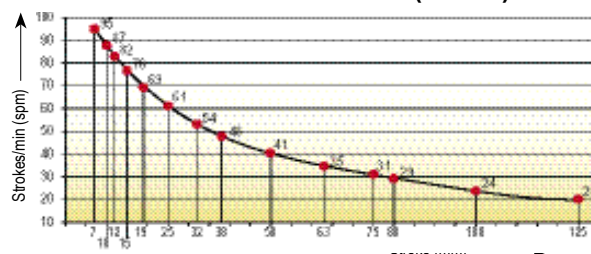

MODEL	Smax mm	Lo mm	Lc mm	V I	Kg
BE-275Vx7	7	44	37	0,004	0,10
BE-275Vx10	10	50	40	0,005	0,12
BE-275Vx12	12	54	42	0,006	0,13
BE-275Vx15	15	60	45	0,007	0,14
BE-275Vx19	19	68	49	0,009	0,15
BE-275Vx25	25	80	55	0,011	0,16
BE-275Vx32	32	94	62	0,014	0,17
BE-275Vx38	38	106	68	0,016	0,19
BE-275Vx50	50	130	80	0,021	0,22
BE-275Vx63	63	156	93	0,026	0,25
BE-275Vx75	75	185	110	0,031	0,26
BE-275Vx80	80	195	115	0,033	0,27
BE-275Vx100	100	235	135	0,041	0,34
BE-275Vx125	125	285	160	0,051	0,37

Color code	Fo daN	Fc daN	P Bar
GRN (Green)	100 (±10)	≈ 160	55
BLU (Blue)	150 (±10)	≈ 250	85
RED (Red)	200 (±15)	≈ 320	110
YEL (Yellow)	320 (±20)	≈ 525	180
(Other forces)	50 - 320	≈ 90 - 525	30 - 180

The black color code denotes a different pressure from that which the customer could choose when ordering between the minimum charging pressure (30Bar) and the maximum charging pressure (180Bar). If not otherwise specified, the gas spring will be supplied in the yellow code version.

How to order

BE-275V x **50** **RED**

Model Stroke Color code

Force/stroke ratio

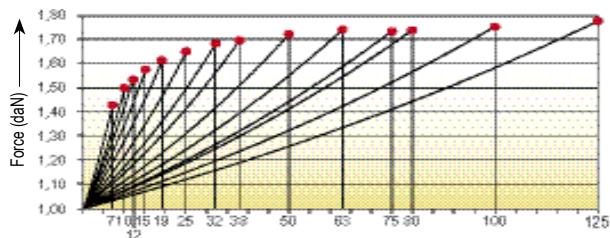

Initial force/charging pressure ratio

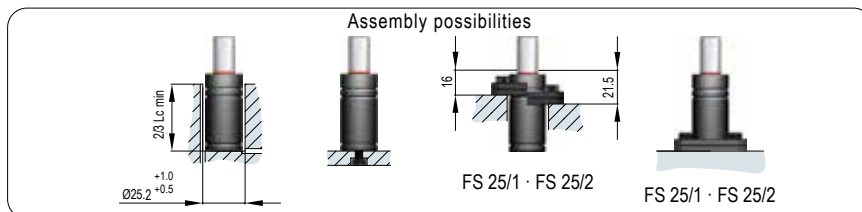
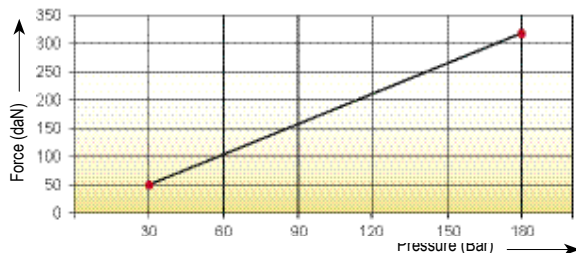

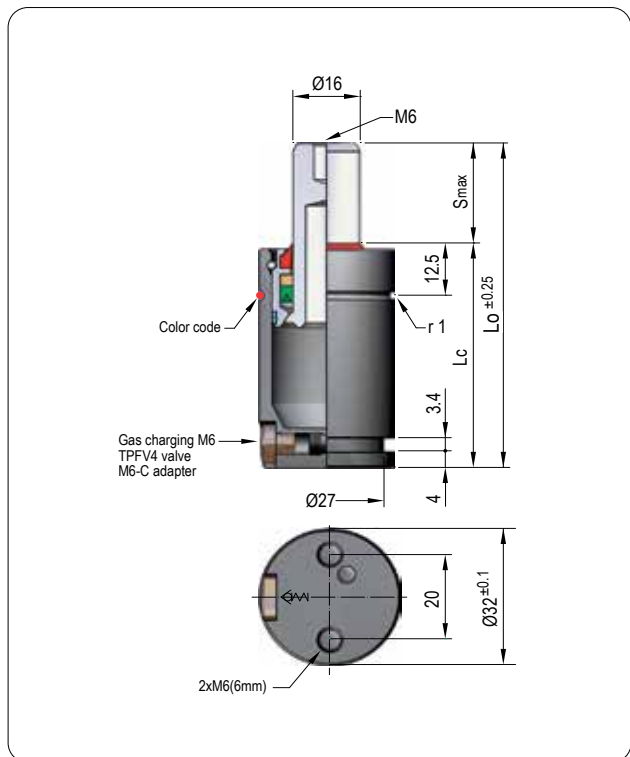

Pressure medium	Gas Nitrogen (N_2)
Max. charging pressure	175 Bar
Min. charging pressure	25 Bar
Rod seal area	2,01 cm^2
Operating temperature	0°C - 80°C
Force increase by temperature	0,33 %/°C
Max. stem speed	1,6 m/s
Maintenance kit	Kit MVS32

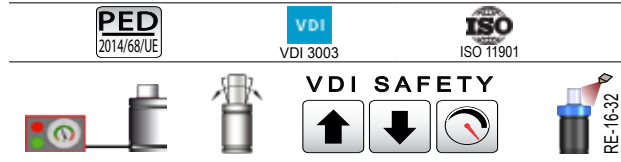

Maximum strokes / minute (at 20°C)

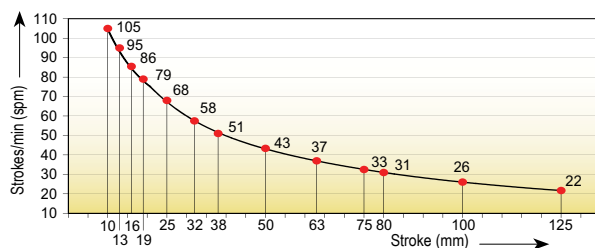

MODEL	Smax mm	Lo mm	Lc mm	V I	Kg
BE-350x10	10	50	40	0,007	0,16
BE-350x13	13	56	43	0,008	0,17
BE-350x16	16	62	46	0,010	0,18
BE-350x19	19	68	49	0,012	0,19
BE-350x25	25	80	55	0,016	0,20
BE-350x32	32	94	62	0,020	0,22
BE-350x38	38	106	68	0,024	0,24
BE-350x50	50	130	80	0,031	0,28
BE-350x63	63	156	93	0,039	0,33
BE-350x75	75	180	105	0,046	0,36
BE-350x80	80	190	110	0,049	0,38
BE-350x100	100	230	130	0,061	0,44
BE-350x125	125	280	155	0,076	0,51

Color code	Fo daN	Fc daN	P Bar
GRN (Green)	50 (±5)	≈ 75	25
BLU (Blue)	150 (±15)	≈ 225	75
RED (Red)	250 (±20)	≈ 370	125
YEL (Yellow)	350 (±20)	≈ 520	175
(Other forces)	50 - 350	≈ 75 - 520	25 - 175

The black color code denotes a different pressure that the customer could choose when ordering between the minimum charging pressure (25Bar) and the maximum charging pressure (175Bar). If not otherwise specified, the gas spring will be supplied in the yellow code version.

How to order

BE-350 x 75 YEL

Model Stroke Color code

Force/stroke ratio

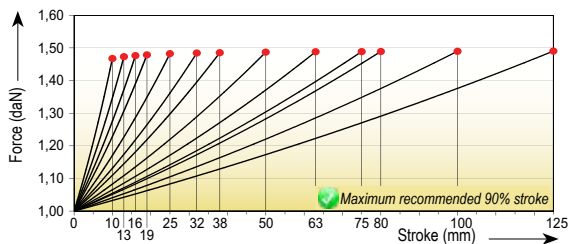

Initial force/charging pressure ratio

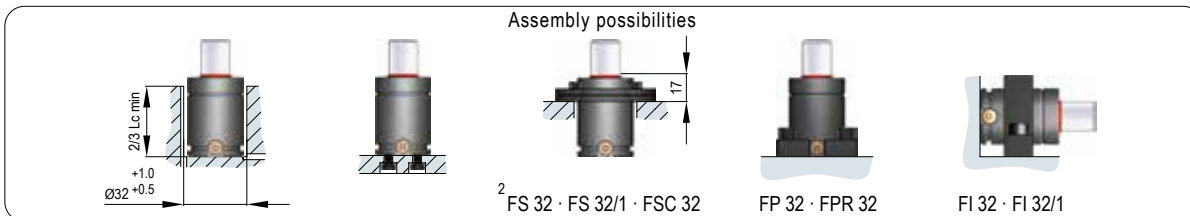
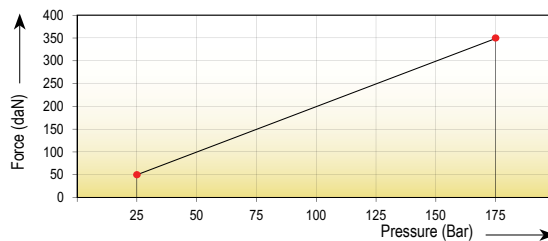

Product improvement through research and development is an ongoing process. All specifications are subject to change without notice.

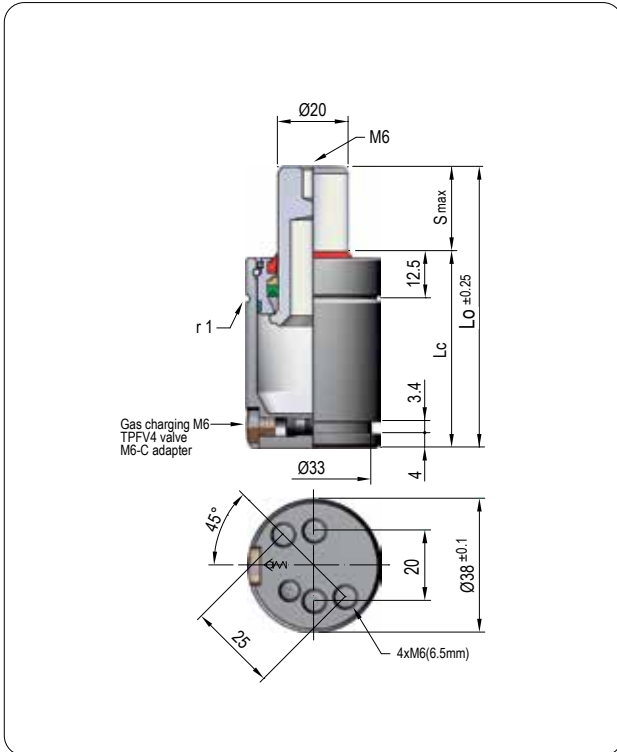

Pressure medium	Nitrogen Gas (N ₂)
Max. charging pressure	150 Bar
Min. charging pressure	35 Bar
Rod seal area	3,14 cm ²
Operating temperature	0°C - 80°C
Force increase by temperature	0,33 %/°C
Max. stem speed	1,6 m/s
Maintenance kit	Kit MVS38

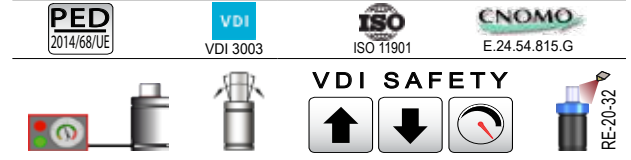

Maximum strokes / minute (at 20°C)

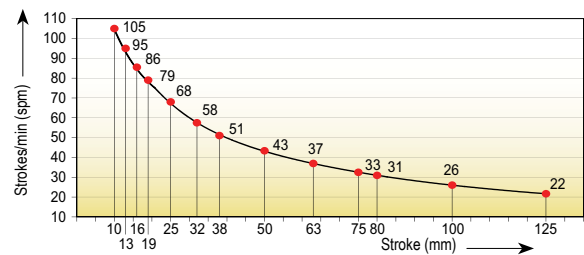

MODEL	S _{max} mm	L ₀ mm	L _c mm	F ₀ daN	90% F daN	100% F _c daN	P Bar	V l	Kg
BE 500x10	10	50	40	470 ±5% (20°C)	640	665	150 (20°C)	0,011	0,25
BE-500x13	13	56	43		645	675		0,014	0,26
BE-500x16	16	62	46		650	680		0,016	0,27
BE-500x19	19	68	49		655	685		0,019	0,28
BE-500x25	25	80	55		660	690		0,025	0,32
BE-500x32	32	94	62		660	695		0,031	0,34
BE-500x38	38	106	68		665	695		0,037	0,38
BE-500x50	50	130	80		665	700		0,048	0,42
BE-500x63	63	156	93		670	700		0,060	0,46
BE-500x75	75	180	105		670	700		0,072	0,50
BE-500x80	80	190	110		670	705		0,076	0,53
BE-500x100	100	230	130		670	705		0,095	0,55
BE-500x125	125	280	155		670	705		0,119	0,68

Force/stroke ratio

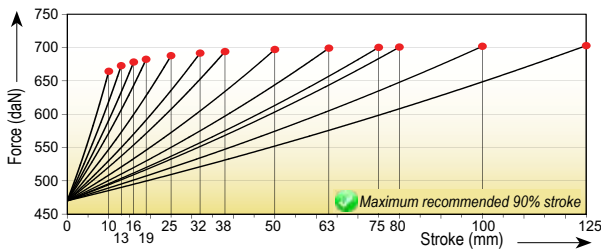

Initial force/charging pressure ratio

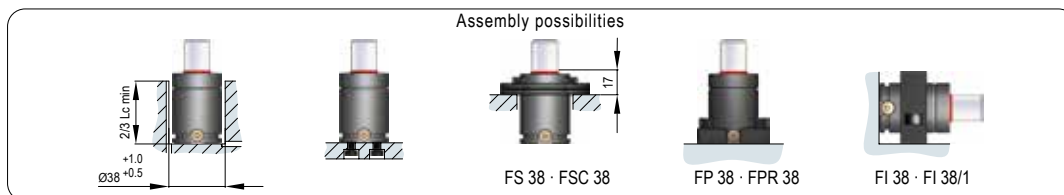
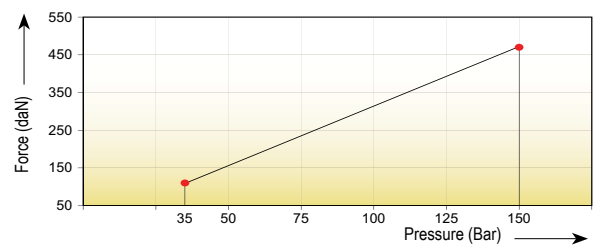

BE-750

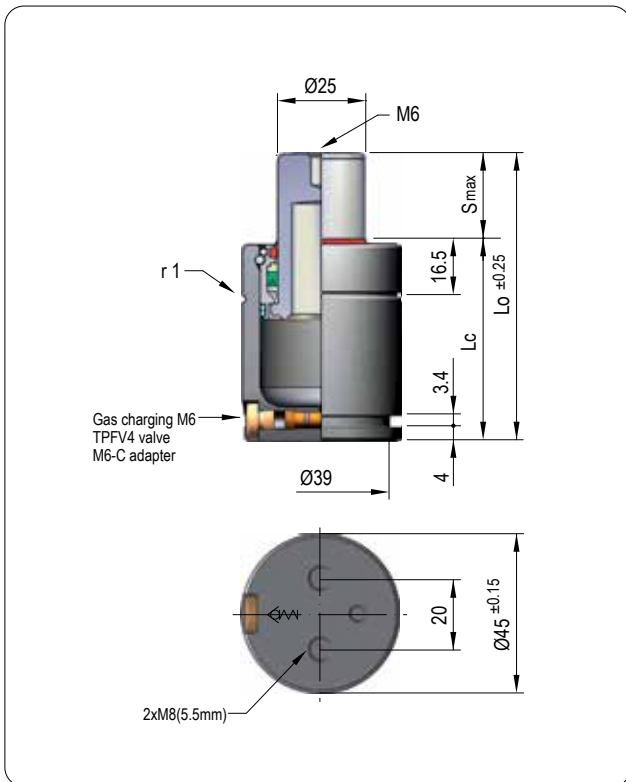

Pressure medium	Nitrogen Gas (N₂)
Max. charging pressure	150 Bar
Min. charging pressure	35 Bar
Rod seal area	4,91 cm²
Operating temperature	0°C - 80°C
Force increase by temperature	0,33 %/°C
Max. stem speed	1,6 m/s
Maintenance kit	Kit MV45

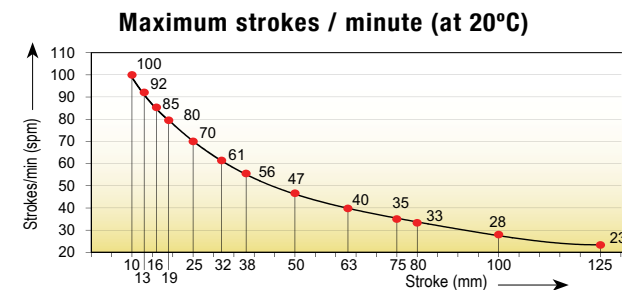

MODEL	S _{max} mm	L _o mm	L _c mm		F _o daN	90%	F daN	100%	F _c daN		P Bar	V l		Kg
BE-750x10	10	52	42		740 ±5% (20°C)		1060		1115		150 (20°C)	0,014		0,32
BE-750x13	13	58	45				1080		1140			0,018		0,35
BE-750x16	16	64	48				1095		1160			0,022		0,39
BE-750x19	19	70	51				1105		1170			0,025		0,40
BE-750x25	25	82	57				1120		1190			0,032		0,44
BE-750x32	32	96	64				1130		1200			0,041		0,47
BE-750x38	38	108	70				1135		1210			0,048		0,50
BE-750x50	50	132	82				1145		1220			0,062		0,59
BE-750x63	63	158	95				1150		1225			0,078		0,65
BE-750x75	75	182	107				1155		1230			0,092		0,80
BE-750x80	80	192	112				1155		1230			0,098		0,85
BE-750x100	100	232	132				1155		1235			0,122		0,98
BE-750x125	125	282	157				1160		1240			0,151		1,15

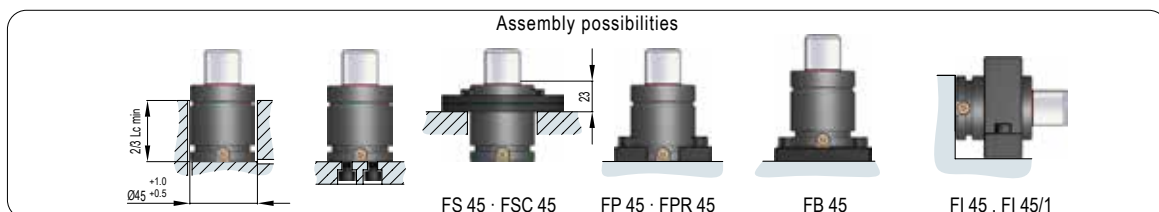
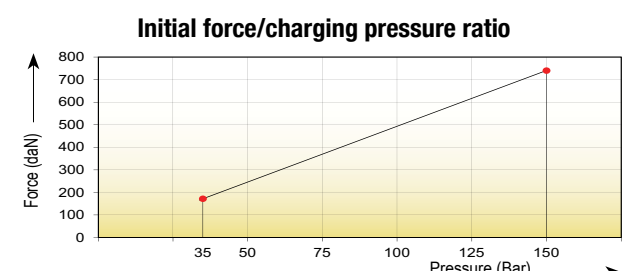
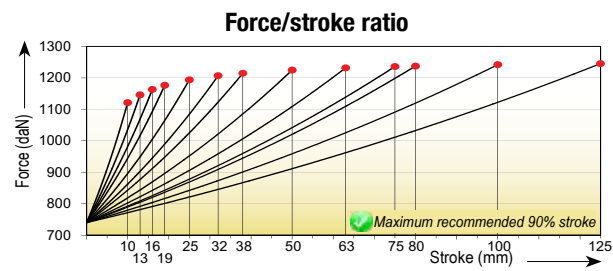

Product improvement through research and development is an ongoing process. All specifications are subject to change without notice.



BE-925

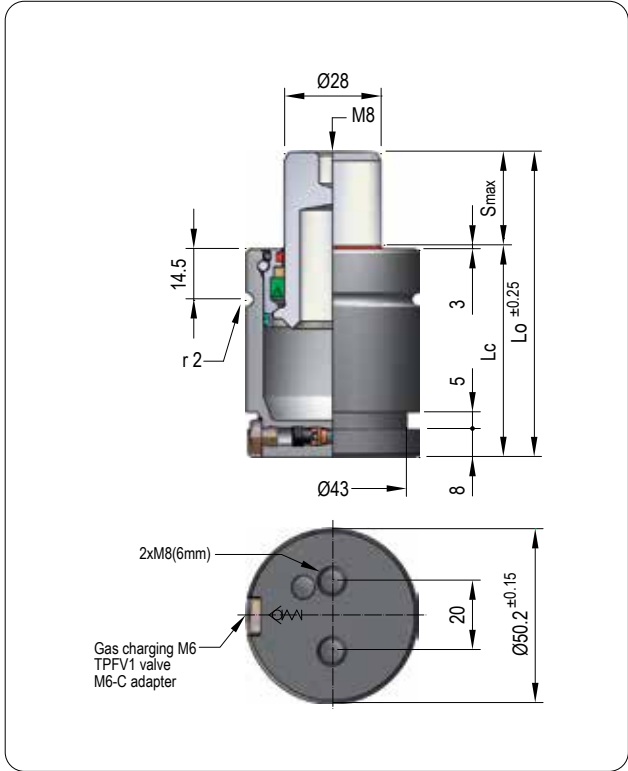

Pressure medium	Nitrogen Gas (N₂)
Max. charging pressure	150 Bar
Min. charging pressure	35 Bar
Rod seal area	6,16 cm²
Operating temperature	0°C - 80°C
Force increase by temperature	0,33 %/°C
Max. stem speed	1,6 m/s
Maintenance kit	Kit M50VS

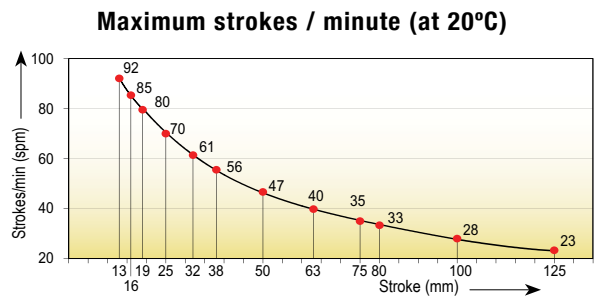
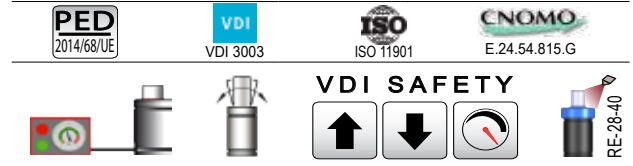

MODEL	S _{max} mm	L ₀ mm	L _c mm	Fo daN	90% F daN	100% F _c daN	P Bar	V l	Kg
BE-925x13	13	64	51	920 ±5% (20°C)	1295	1355	150 (20°C)	0,025	0,53
BE-925x16	16	70	54		1315	1380		0,030	0,55
BE-925x19	19	76	57		1330	1400		0,034	0,58
BE-925x25	25	88	63		1355	1430		0,044	0,62
BE-925x32	32	102	70		1370	1450		0,054	0,67
BE-925x38	38	114	76		1380	1460		0,064	0,72
BE-925x50	50	138	88		1395	1480		0,082	0,82
BE-925x63	63	164	101		1405	1490		0,102	0,93
BE-925x75	75	188	113		1410	1495		0,121	1,10
BE-925x80	80	198	118		1410	1500		0,128	1,15
BE-925x100	100	238	138		1415	1505		0,159	1,25
BE-925x125	125	288	163		1420	1515		0,198	1,45

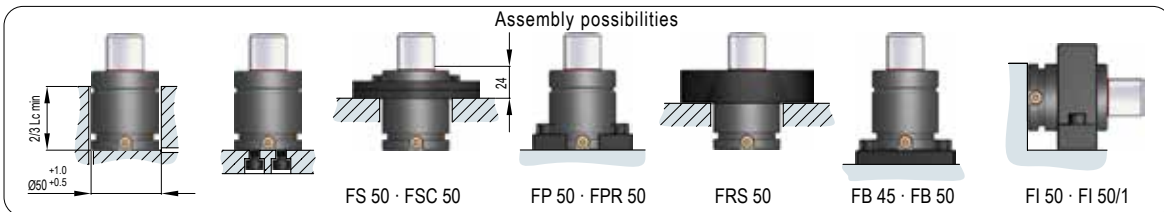
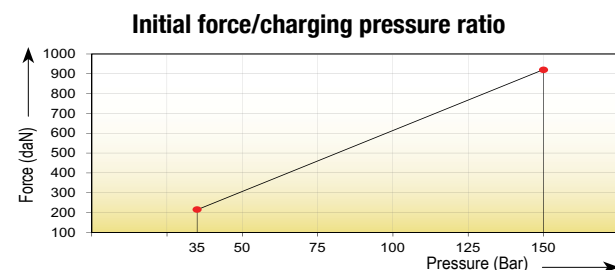
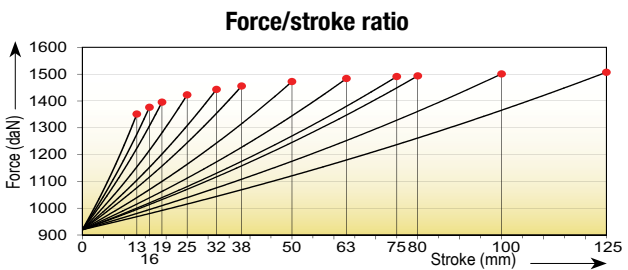



BE-1500

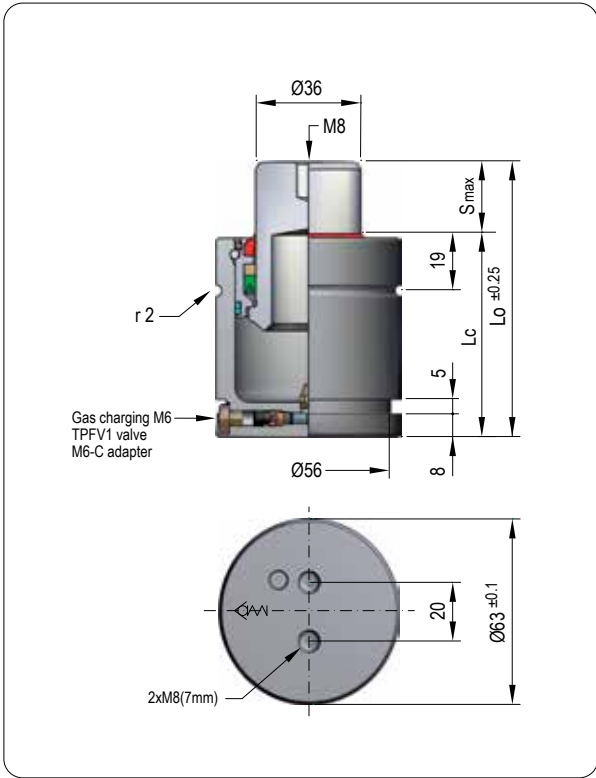

Pressure medium	Nitrogen Gas (N₂)
Max. charging pressure	150 Bar
Min. charging pressure	35 Bar
Rod seal area	10,18 cm²
Operating temperature	0°C - 80°C
Force increase by temperature	0,33 %/°C
Max. stem speed	1,6 m/s
Maintenance kit	Kit M63V



Maximum strokes / minute (at 20°C)

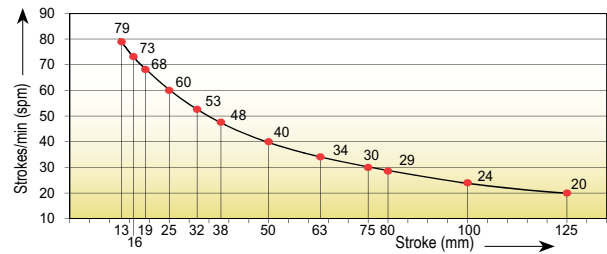

MODEL	S _{max} mm	Lo mm	Lc mm	Fo daN	90% F daN	100% Fc daN	P Bar	V l	Kg
BE-1500x13	13	70	57	1500 ±5% (20°C)	2135	2245	150 (20°C)	0,040	0,95
BE-1500x16	16	76	60		2165	2275		0,048	0,97
BE-1500x19	19	82	63		2200	2320		0,054	1,15
BE-1500x25	25	94	69		2235	2365		0,069	1,27
BE-1500x32	32	108	76		2265	2405		0,086	1,35
BE-1500x38	38	120	82		2280	2425		0,101	1,40
BE-1500x50	50	144	94		2305	2455		0,131	1,55
BE-1500x63	63	170	107		2320	2470		0,162	1,71
BE-1500x75	75	194	119		2330	2485		0,192	1,83
BE-1500x80	80	204	124		2335	2490		0,204	1,95
BE-1500x100	100	244	144		2345	2500		0,253	2,32
BE-1500x125	125	294	169		2355	2510		0,315	2,82

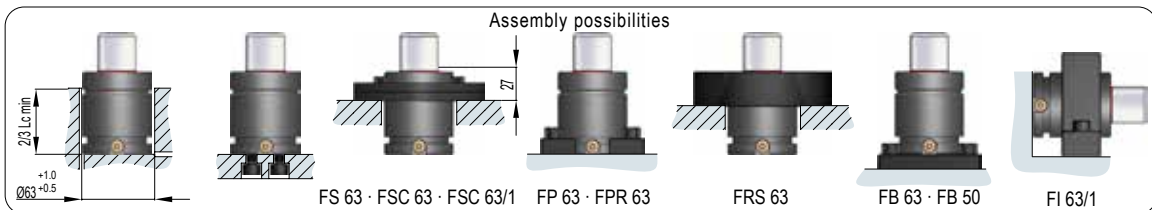
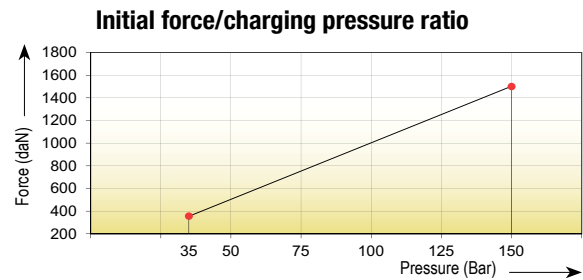
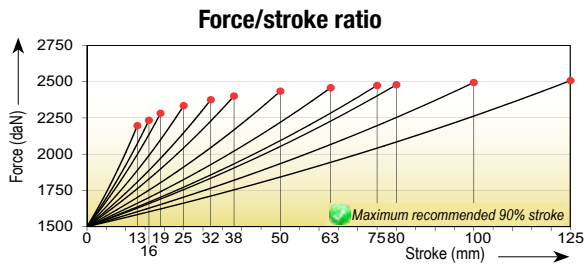

Product improvement through research and development is an ongoing process. All specifications are subject to change without notice.

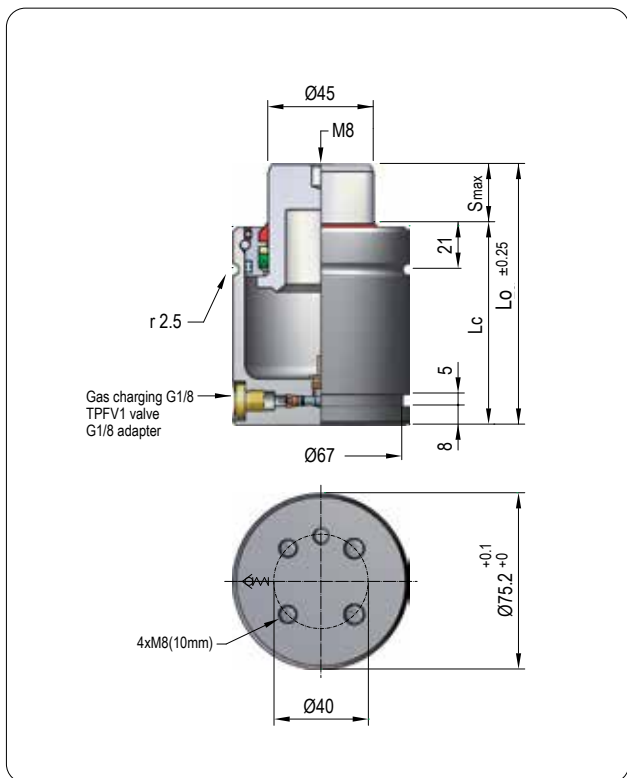

Pressure medium	Nitrogen Gas (N₂)
Max. charging pressure	150 Bar
Min. charging pressure	35 Bar
Rod seal area	15,90 cm²
Operating temperature	0°C - 80°C
Force increase by temperature	0,33 %/°C
Max. stem speed	1,6 m/s
Maintenance kit	Kit M75.1

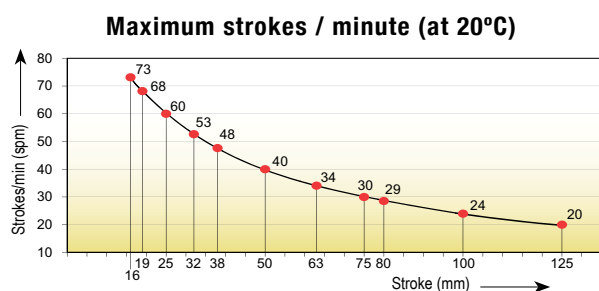

MODEL	Smax mm	Lo mm	Lc mm	Fo daN	90% F daN	100% Fc daN	P Bar	V l	Kg
BE-2400x16	16	77	61	2400 ±5% (20°C)	3385	3550	150 (20°C)	0,078	1,40
BE-2400x19	19	83	64		3420	3595		0,090	1,43
BE-2400x25	25	95	70		3470	3650		0,115	1,45
BE-2400x32	32	109	77		3505	3695		0,144	1,65
BE-2400x38	38	121	83		3525	3725		0,168	1,70
BE-2400x50	50	145	95		3555	3760		0,218	1,80
BE-2400x63	63	171	108		3575	3785		0,271	2,10
BE-2400x75	75	195	120		3585	3800		0,321	2,15
BE-2400x80	80	205	125		3590	3805		0,341	2,25
BE-2400x100	100	245	145		3600	3820		0,424	2,60
BE-2400x125	125	295	170	3610	3830	0,527	3,10		

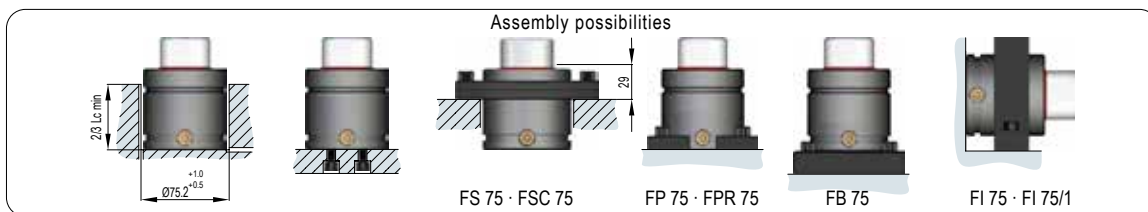
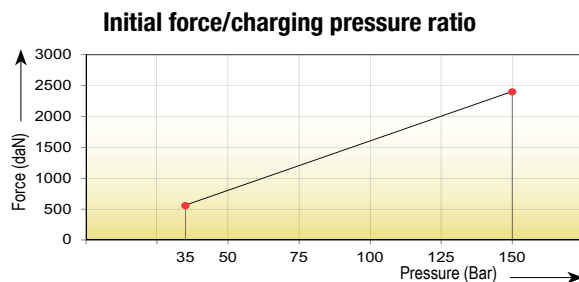
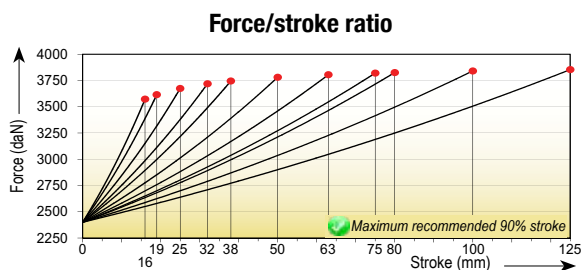

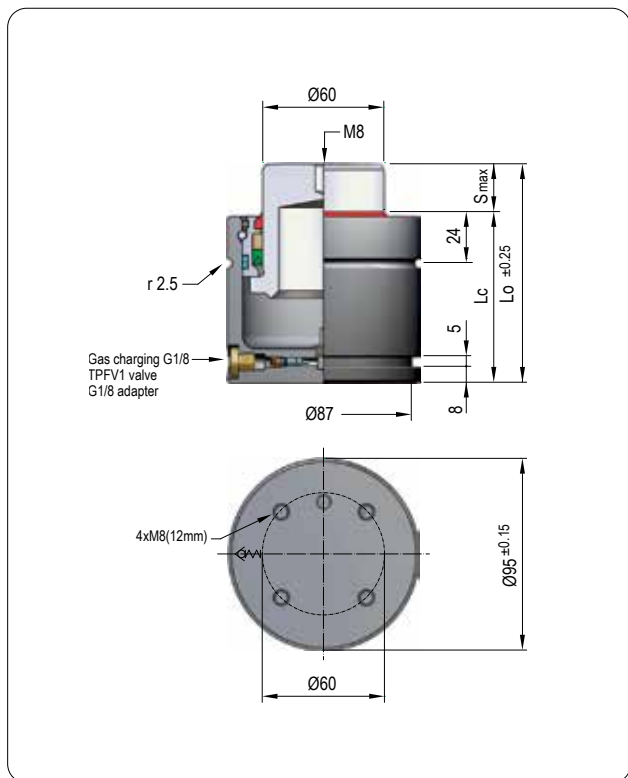

Pressure medium	Nitrogen Gas (N₂)
Max. charging pressure	150 Bar
Min. charging pressure	35 Bar
Rod seal area	28,27 cm²
Operating temperature	0°C - 80°C
Force increase by temperature	0,33 %/°C
Max. stem speed	1,6 m/s
Maintenance kit	Kit M95



Maximum strokes / minute (at 20°C)

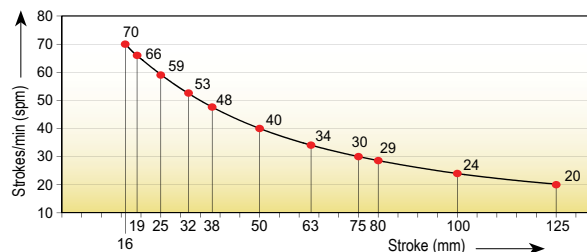

MODEL	S _{max} mm	L ₀ mm	L _c mm	F ₀ daN	90% F daN	100% F _c daN	P Bar	V l	Kg
BE-4200x16	16	90	74	4200 ±5% (20°C)	5890	6155	150 (20°C)	0,146	2,80
BE-4200x19	19	96	77		6000	6285		0,165	2,90
BE-4200x25	25	108	83		6160	6485		0,204	3,10
BE-4200x32	32	122	90		6285	6645		0,250	3,25
BE-4200x38	38	134	96		6370	6745		0,290	3,70
BE-4200x50	50	158	108		6480	6885		0,368	3,90
BE-4200x63	63	184	121		6565	6990		0,453	4,40
BE-4200x75	75	208	133		6615	7055		0,532	4,75
BE-4200x80	80	218	138		6635	7075		0,565	4,90
BE-4200x100	100	258	158		6690	7145		0,695	6,00
BE-4200x125	125	308	183		6735	7205		0,859	6,50

Force/stroke ratio

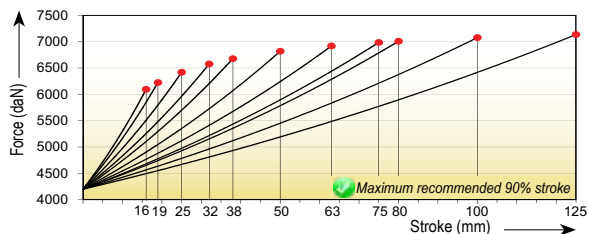

Initial force/charging pressure ratio

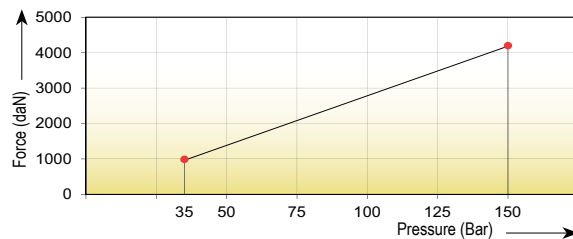

Assembly possibilities

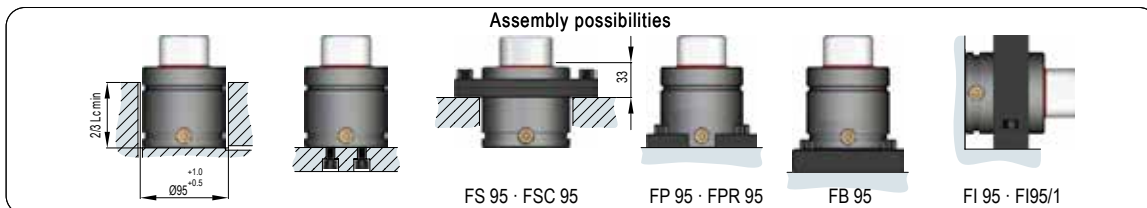

FS 95 · FSC 95

FP 95 · FPR 95

FB 95

FI 95 · FI95/1

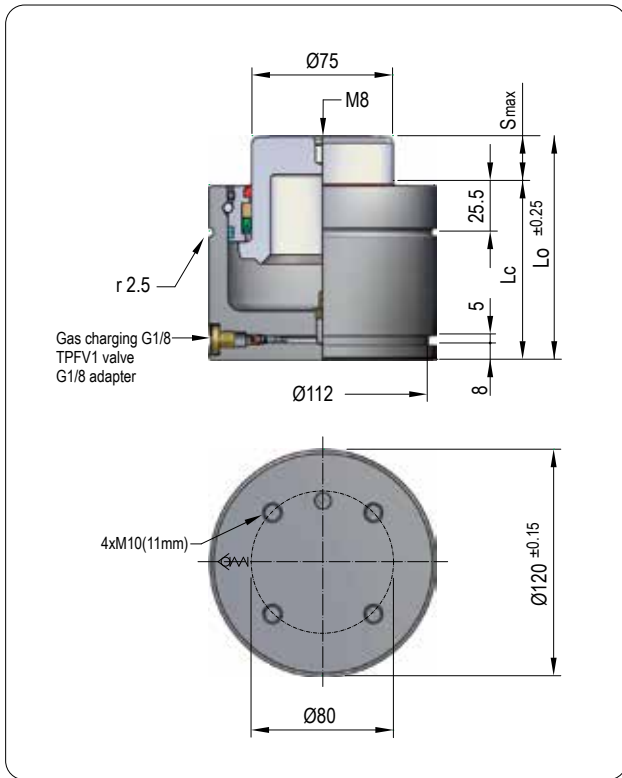

Pressure medium	Nitrogen Gas (N₂)
Max. charging pressure	150 Bar
Min. charging pressure	35 Bar
Rod seal area	44,18 cm²
Operating temperature	0°C - 80°C
Force increase by temperature	0,33 %/°C
Max. stem speed	1,6 m/s
Maintenance kit	Kit M120V



Maximum strokes / minute (at 20°C)

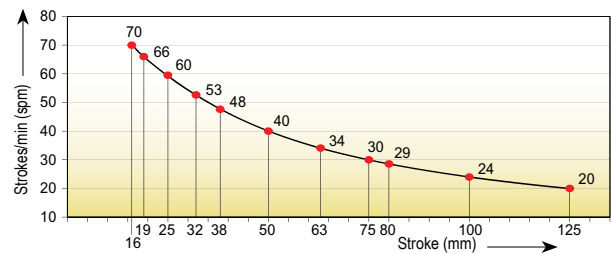

MODEL	Smax mm	Lo mm	Lc mm		Fo daN	90%	F daN	100%	Fc daN		P Bar	V l		Kg	
BE-6600x16	16	100	84	6600 ±5% (20°C)	6600 ±5% (20°C)		9165		9575		150 (20°C)	0,230		5,20	
BE-6600x19	19	106	87				9335		9780					0,260	5,35
BE-6600x25	25	118	93				9590		10090					0,322	5,40
BE-6600x32	32	132	100				9795		10345					0,393	5,60
BE-6600x38	38	144	106				9925		10505					0,455	5,95
BE-6600x50	50	168	118				10105		10730					0,577	6,30
BE-6600x63	63	194	131				10235		10895					0,710	6,70
BE-6600x75	75	218	143				10320		11000					0,833	7,05
BE-6600x80	80	228	148				10350		11040					0,884	7,55
BE-6600x100	100	268	168				10440		11150					1,089	8,40
BE-6600x125	125	318	193				10510		11245					1,345	9,45

Force/stroke ratio

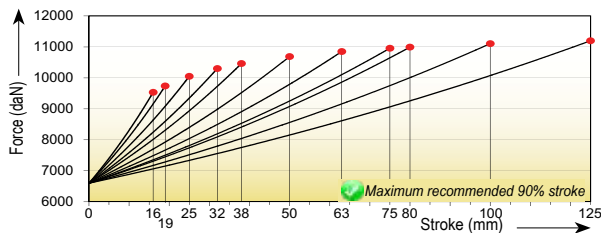

Initial force/charging pressure ratio

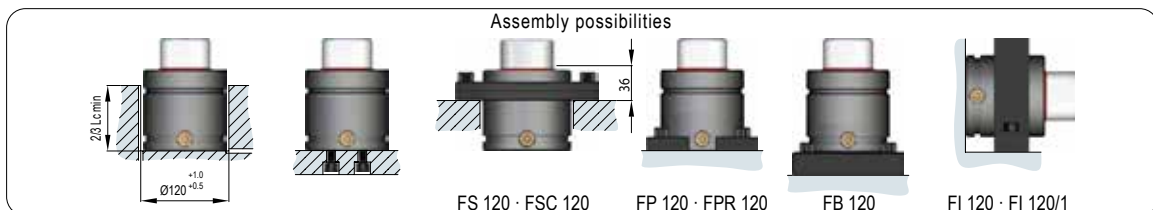
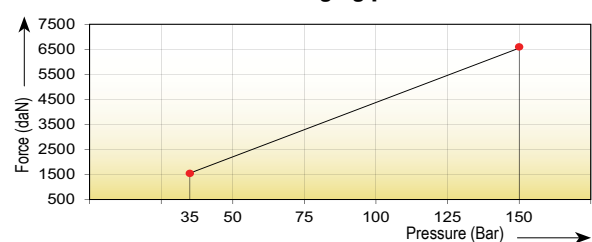

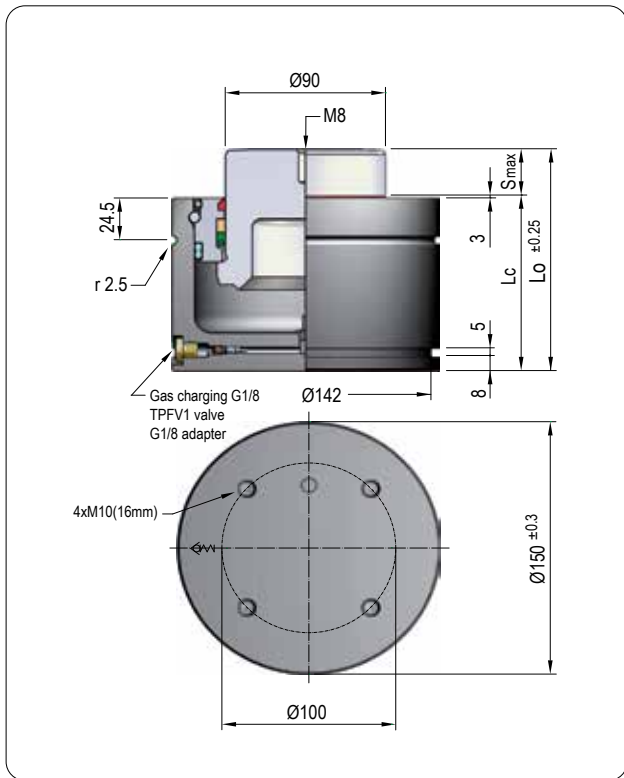

Pressure medium	Nitrogen Gas (N₂)
Max. charging pressure	150 Bar
Min. charging pressure	35 Bar
Rod seal area	63,62 cm²
Operating temperature	0°C - 80°C
Force increase by temperature	0,33 %/°C
Max. stem speed	1,6 m/s
Maintenance kit	Kit M150



Maximum strokes / minute (at 20°C)

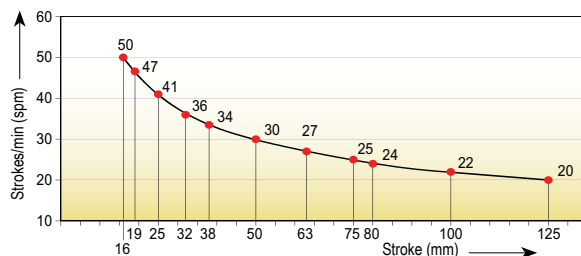

MODEL	Smax mm	Lo mm	Lc mm	Fo daN	90% F daN	100% Fc daN	P Bar	V l	Kg
BE-9500x16	16	110	94	9500 ±5% (20°C)	13455	14095	150 (20°C)	0,315	9,50
BE-9500x19	19	116	97		13665	14355		0,361	9,60
BE-9500x25	25	128	103		13980	14740		0,451	9,85
BE-9500x32	32	142	110		14225	15045		0,557	10,50
BE-9500x38	38	154	116		14375	15230		0,647	10,85
BE-9500x50	50	178	128		14580	15490		0,829	11,45
BE-9500x63	63	204	141		14725	15670		1,025	12,05
BE-9500x75	75	228	153		14820	15790		1,206	12,45
BE-9500x80	80	238	158		14850	15830		1,282	13,70
BE-9500x100	100	278	178		14945	15950		1,584	14,80
BE-9500x125	125	328	203	15025	16050	1,961	15,95		

Force/stroke ratio

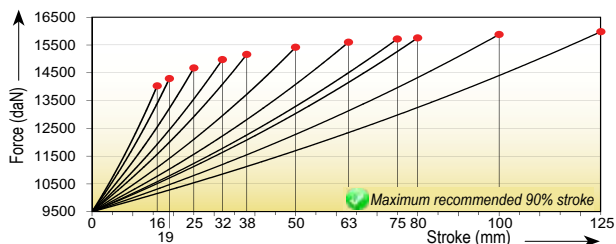

Initial force/charging pressure ratio

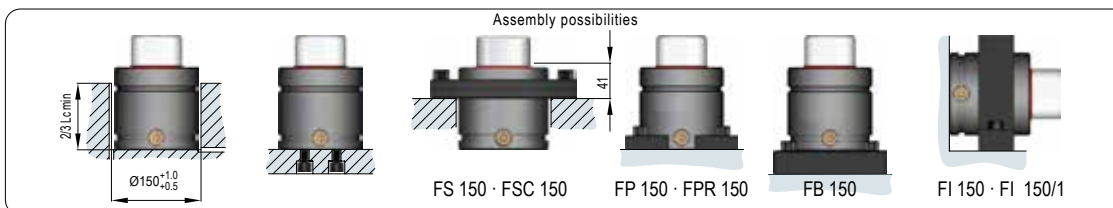
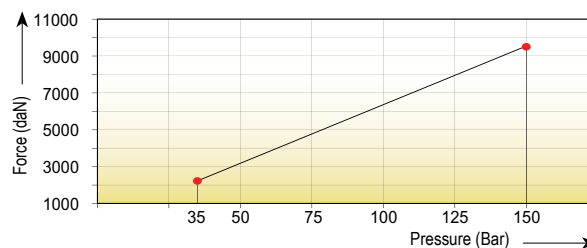

Product improvement through research and development is an ongoing process. All specifications are subject to change without notice.

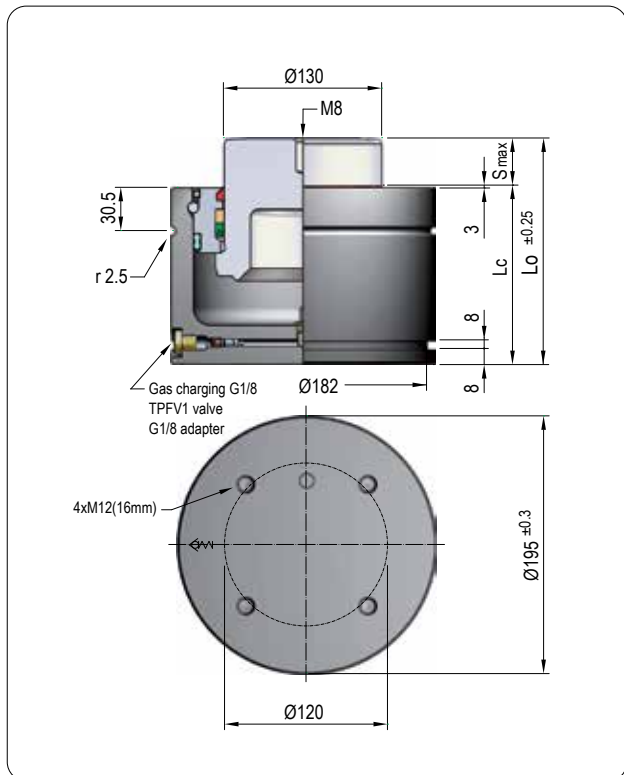

Pressure medium	Nitrogen Gas (N₂)
Max. charging pressure	150 Bar
Min. charging pressure	35 Bar
Rod seal area	132,73 cm²
Operating temperature	0°C - 80°C
Force increase by temperature	0,33 %/°C
Max. stem speed	1 m/s
Maintenance kit	Kit M195



Maximum strokes / minute (at 20°C)

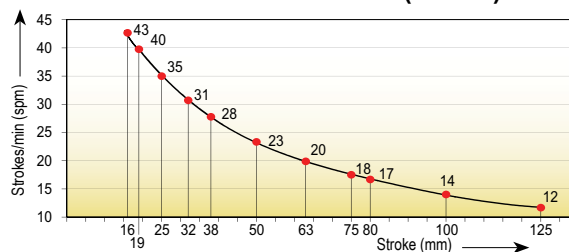

MODEL	Smax mm	Lo mm	Lc mm	Fo daN	F daN	Fc daN	P Bar	V l	Kg
BE-20000x16	16	142	126	20000 ±5% (20°C)	28260	29645	150 (20°C)	0,647	20,85
BE-20000x19	19	148	129		28990	30540		0,725	21,45
BE-20000x25	25	160	135		30135	31960		0,880	22,10
BE-20000x32	32	174	142		31115	33190		1,061	22,85
BE-20000x38	38	186	148		31755	34005		1,217	23,45
BE-20000x50	50	210	160		32690	35200		1,528	24,70
BE-20000x63	63	236	173		33380	36095		1,865	26,10
BE-20000x75	75	260	185		33850	36700		2,176	27,25
BE-20000x80	80	270	190		34005	36910		2,305	28,20
BE-20000x100	100	310	210		34510	37570		2,824	31,10
BE-20000x125	125	360	235	34940	38135	3,472	35,20		

Force/stroke ratio

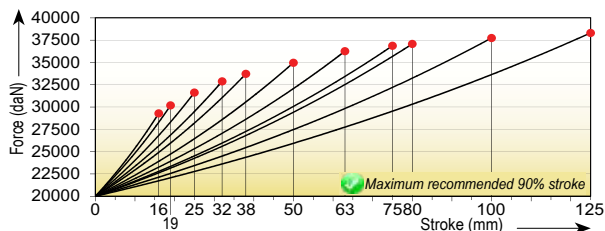

Initial force/charging pressure ratio

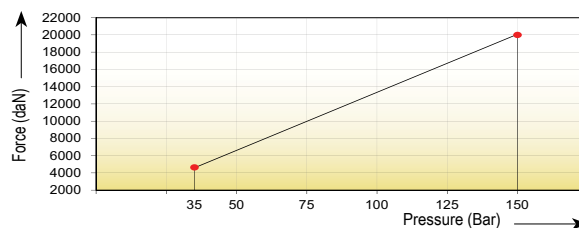

Assembly possibilities

