

Ball Bearing Cages

Operating Conditions

For optimum performance guide pins should be mounted in the punch holder. This allows the ball cage to reposition itself, if preload is relieved on each press stroke. Complete assemblies (guide pin, ball cage and bushing) should be ordered to insure proper fit.

Recommended Lubrication

We recommend lubricating the ball bushing assembly once each 8 hour shift. Use a refined mineral oil with a viscosity of 290/340 SSU at 100° F, combining "EP" additives and rust inhibitors, such as Mobil Compound AA or Mobil Gear 626.

Installation Instructions for Sleeve Bushings Using Bushing Mount

1. Degrease bushing OD and die shoe bore with alcohol, acetone or other volatile solvent and wipe dry.
2. Apply Bushing Mount sparingly to both surfaces.
3. Wring bushing into die shoe.
4. Allow 4-hour cure at 72°F. To accelerate cure, heat with heat-lamp. Do not disturb bushing until cure is complete.
5. Honing is not required after installation.

Precision Guide Pins (-825) Demountable Pins (-835), and Double Diameter Pins (-55)

You can use any of our guide pins in ball bearing applications because each of the 3 styles is designed for dual purpose in both friction solid guiding and ball bearing guiding.

Vacuum degassed, ball bearing quality steel is induction hardened to 60-64 Rc, then core tempered for toughness. This produces an optimum combination of wear resistance for long

operating life and shock resistance for safety.

The guide pin retains the ball cage by means of a washer assembly. The cage is free to rotate 360°, so scoring and tracking on the guide pin surface are eliminated or reduced.

Our guide pins are interchangeable with all the major brands.

Ball Bearing Cages (-8225)

Our Ball Cages use AFBMA Grade 10 precision ball bearings, accurate to within .0001". These ball bearing have been chosen for their high hardness and excellent resistance to wear and deformation. They are retained securely in place by a hardened aluminum alloy cage, heat treated for toughness and wear resistance.

Each ball bearing is held in place with 360° staking. This is a safer design than two or four point staking.

Failure tests show that a 360° staked ball requires a substantially higher force to become dislodged.

Ready Ball Cages are free to rotate within the ball bushing assembly, so wear on the guide pin and bushing is reduced. The ball bearings are arranged in a double spiral pattern, so that each ball bearing travels along its own unique path. Tracking is reduced and operating life is enhanced.

Demountable Ball Bearing Bushings (-855) and Straight Sleeve Bushings (-865)

We offer two types of ball bearing bushings. Our Demountable Ball Bearing Bushings are flange mounted and held in place with toe clamps and screws. They are interchangeable with familiar brands of demountable ball bushings.

Our Straight Sleeve bushings offer something quite new. All sleeve bushings 1 1/2" in diameter and larger incorporate our patented Ring System clamping groove, which provides several benefits. Please refer to the following page for details.

If you prefer, however, you can secure our sleeve bushings in the traditional

manner with Bushing Mount. Up to eleven tons of force are required to dislodge the bushing once the Bushing Mount has properly cured. Please follow the assembly procedure outlined in the side panel on this page. Bushing Mount compound is available upon request.

Our ball bearing bushings are interchangeable with most major brands; for brands with a smaller register fit than ours, we have left the OD of our straight sleeve bushing soft, enabling you to turn down the OD to match. See your READY representative for details.

The Ring System - Our Straight Sleeve Bushing Has Just Become Demountable

Our patented Ring System consists of a slightly curved clamp which fits into a 4° angled groove. As the clamping screw is tightened the clamp wedges against the slot, holding the bushing securely in place.

This design produces real benefits. Since the Ring System makes the sleeve bushing easy to assemble and disassemble, die building and maintenance are simplified. Ring System bushings are less costly to produce than demountable bushings, so you save on purchase cost.

In addition, Ring System bushings give you more die space. You can see in the table below that the Ring System sleeve bushing takes up less space than a demountable ball bearing bushing of traditional design.

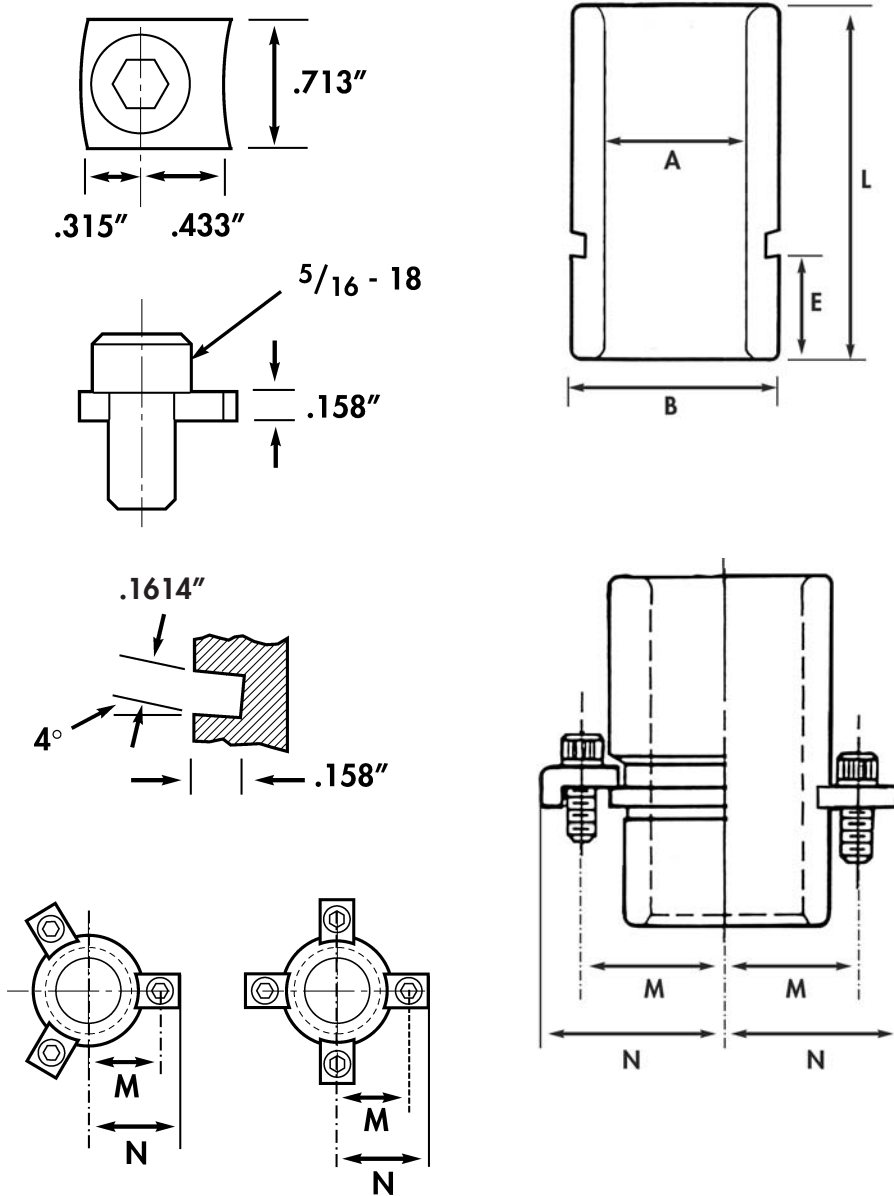

Clamp Data

Pin Diameter	Demountable Bushing					Ring System Sleeve Bushing				
	M	N	Clamps per Bushing	Clamp	Screw	M	N	Clamps per Bushing	Clamp	Screw
1"	1.313	1.688	3			-	-	-		
1 1/4"	1.438	1.813	3			-	-	-		
1 1/2"	1.688	2.063	4	6-93-1	5/16 - 18 X 3/4 lg	1.513	1.846	4	6-B2-1	5/16 - 18 X 3/4 lg
1 3/4"	1.813	2.188	4			1.657	1.972	4		
2"	2.063	2.438	4			1.909	2.224	4		
2 1/2"	2.313	2.688	4			2.161	2.476	4		
3"	2.625	3.000	4			-	-	-		